

## INSTALLER GUIDE

# Dream 2

**INSET LIVE FUEL EFFECT GAS FIRE**

**INCORPORATING THE  
VALOR *FireSlide* CONTROL**



**Model 641**

(GC No. 32-032-49)

**THIS APPLIANCE IS FOR USE WITH NATURAL GAS (G20)  
WHEN CONVERTED USING CONVERSION KIT NO. 0591301 THIS  
APPLIANCE IS FOR USE WITH PROPANE GAS (G31)  
THIS APPLIANCE IS FOR USE IN THE UNITED KINGDOM (GB) AND THE  
REPUBLIC OF IRELAND (IE) ONLY.**

We trust that these instructions give sufficient details to enable this appliance to be installed and maintained satisfactorily. However, if further information is required, our

**Valor Technical Helpline** will be pleased to help.

Telephone **08706 061 065**

**INSTALLER: Please leave this guide with the owner**

# INSTALLER'S GUIDE

## Safety First.

Valor fires are CE Approved and designed to meet the appropriate British Standards and Safety Marks.



## Quality and Excellence.

At the heart of every Valor fire.

All Valor fires are manufactured to the highest standards of quality and excellence and are manufactured under a BS EN ISO 9001 quality system accepted by the British Standards Institute.



## The Highest Standards

Valor is a member of the Society of British Gas Industries which works to ensure high standards of safety, quality and performance.



## Careful Installation

Valor is a CORGI registered company. All our gas fires must be installed by a competent CORGI Registered Installer in accordance with our Installer Guide and should not be fitted directly on to a carpet or floor of combustible material.



Valor Heating, Erdington, Birmingham B24 9QP

[www.valor.co.uk](http://www.valor.co.uk)

Because our policy is one of constant development and improvement, details may vary slightly from those given in this publication

# INSTALLER'S GUIDE

## SAFETY

### Installer

- Before continuing any further with the installation of this appliance please read the following guide to manual handling
- The lifting weight of this appliance is 24.0 kg. One person should be sufficient to lift the fire. If for any reason this weight is considered too heavy then obtain assistance.
- When lifting always keep your back straight. Bend your legs and not your back.
- Avoid twisting at the waist. It is better to reposition your feet.
- Avoid upper body/top heavy bending. Do not lean forward or sideways whilst handling the fire.
- Always grip with the palm of the hand. Do not use the tips of fingers for support.
- Always keep the fire as close to the body as possible. This will minimise the cantilever action.
- Use gloves to provide additional grip.
- Always use assistance if required.

# INSTALLER'S GUIDE

## CONTENTS

<b>SAFETY</b> .....	<b>3</b>
<b>1 APPLIANCE DATA</b> .....	<b>5</b>
<b>2 GENERAL INSTALLATION REQUIREMENTS</b> .....	<b>6</b>
<b>3 PACK CONTENTS</b> .....	<b>12</b>
<b>4 FIREPLACE CHECK</b> .....	<b>15</b>
<b>5 IGNITION CHECK</b> .....	<b>17</b>
<b>6 GAS SUPPLY CONNECTION</b> .....	<b>18</b>
<b>7 PREPARING APPLIANCE FOR INSTALLATION</b> .....	<b>19</b>
<b>8 HOTBOX INSTALLATION</b> .....	<b>21</b>
8.1 Method 1 - Front Fixing to Fireplace Surround .....	21
8.2 Method 2 - Cable Retention and Floor Fixing.....	22
8.3 Sealing Floor Front - All installations .....	24
<b>9 BURNER &amp; SUPPLY PIPE INSTALLATION</b> .....	<b>25</b>
<b>10 CERAMIC WALLS INSTALLATION</b> .....	<b>27</b>
<b>11FRONT SURROUND &amp; CONTROL LINKAGE INSTALLATION</b> .....	<b>28</b>
<b>12CERAMIC COALS INSTALLATION</b> .....	<b>30</b>
<b>13FRONT / CASTINGS INSTALLATION</b> .....	<b>34</b>
<b>14FULL OPERATING CHECKS</b> .....	<b>35</b>
14.1 Check the Control Settings .....	35
14.2 Check For Spillage.....	36
14.3 Flame Supervision & Spillage Monitoring System.....	36
<b>15FINAL REVIEW</b> .....	<b>38</b>
<b>16SERVICING &amp; PARTS REPLACEMENT</b> .....	<b>39</b>
16.1 Checking the aeration setting of the burner .....	39
16.2 To Remove the Ignition Microswitch.....	40
16.3 To Remove the Gas Shut-Off Microswitch.....	41
16.4 To Remove the Fire Front Surround.....	41
16.5 To Replace the Control Slide Unit .....	42
16.6 To Replace the Control Slide Button.....	42
16.7 To Remove the Burner Unit .....	42
16.8 To Remove the Electronic Ignition Generator .....	42
16.9 To Remove the Thermocouple Interrupter Block .....	43
16.10 To Remove the Pilot Unit .....	44
16.11 To Remove the Shut-Off Tap.....	45
16.12 To Remove the Gas Flow Rate Controller.....	46
16.13 To Remove the Main Burner Injector .....	46
16.14 To Replace Burner Plaques.....	48
16.15 To Remove the Appliance from the Fireplace.....	49
<b>17SHORT LIST OF SPARES</b> .....	<b>50</b>

# INSTALLER'S GUIDE

## 1 APPLIANCE DATA

This product uses fuel effect pieces, burner compartment walls and gaskets containing Refractory Ceramic Fibres (RCF), which are man-made vitreous silicate fibres. Excessive exposure to these materials may cause irritation to eyes, skin and respiratory tract. Consequently, it is important to take care when handling these articles to ensure that the release of dust is kept to a minimum. To ensure that the release of fibres from these RCF articles is kept to a minimum, during installation and servicing we recommend that you use a HEPA filtered vacuum to remove any dust and soot accumulated in and around the fire before and after working on the fire. When replacing these articles we recommend that the replaced items are not broken up, but are sealed within a heavy duty polythene bag, clearly labelled as RCF waste. This is not classified as “hazardous waste” and may be disposed of at a tipping site licensed for the disposal of industrial waste. Protective clothing is not required when handling these articles, but we recommend you follow the normal hygiene rules of not smoking, eating or drinking in the work area and always wash your hands before eating or drinking.

This appliance does not contain any component manufactured from asbestos or asbestos related products.

The appliance data label is located on a ‘pivot’ plate at the base of the fire. This can be seen by pulling on the raised tab.

Gas	Natural (G20)	Propane (G31)*
Inlet Pressure	20mbar	37mbar
Input - Max. (Gross)	6.85kW (23,400 Btu/h)	6.7kW (22,860 Btu/h)
Input - Min. (Gross)	2.7kW (9,410 Btu/h)	4.3kW (14,670 Btu/h)
Burner Test Pressure (Cold)	17.0 ± 0.75mbar (6.82 ± 0.3in w.g.)	35.85 ± 0.75mbar (14.4 ± 0.3in w.g.)
Gas Connection	8mm pipe	8mm pipe
Burner Injector	Bray Cat. 18U Size 420	Stereomatic Size 170
Pilot & Atmosphere Sensing Device	SIT Ref. OP NG9030	SIT Ref. OP LPG9222
Ignition	Electronic (Battery 9V PP3)	Electronic (Battery 9V PP3)
Aeration	Non-adjustable	Non-adjustable

\*When converted using kit 0591301.

# INSTALLER'S GUIDE

## 2 GENERAL INSTALLATION REQUIREMENTS

**2.1** The installation must be in accordance with these instructions.

For the user's protection, in the United Kingdom it is the law that all gas appliances are installed by competent persons in accordance with the current edition of the Gas Safety (Installation and Use) Regulations. Failure to install the appliance correctly could lead to prosecution. The Council for the Registration of Gas Installers (CORGI) requires its members to work to recognised standards.

In the United Kingdom the installation must also be in accordance with:

All the relevant parts of local regulations.

All relevant codes of practice.

The relevant parts of the current editions of the following British Standards:-

BS 715	BS 1289 Part 2	BS 5440 Part 1	BS 6461 Part 1
BS 1251	BS EN 1806	BS 5440 Part 2	BS 6891
BS 1289 Part 1	BS 4543 Part 2	BS 5871 Part 2	BS 8303

In England and Wales, the current edition of the Building Regulations issued by the

Department of the Environment and the Welsh Office

In Scotland, the current edition of the Building Standards (Scotland) Regulations issued by the Scottish Executive.

In Northern Ireland, the current edition of the Building regulations (Northern Ireland) issued by the Department of

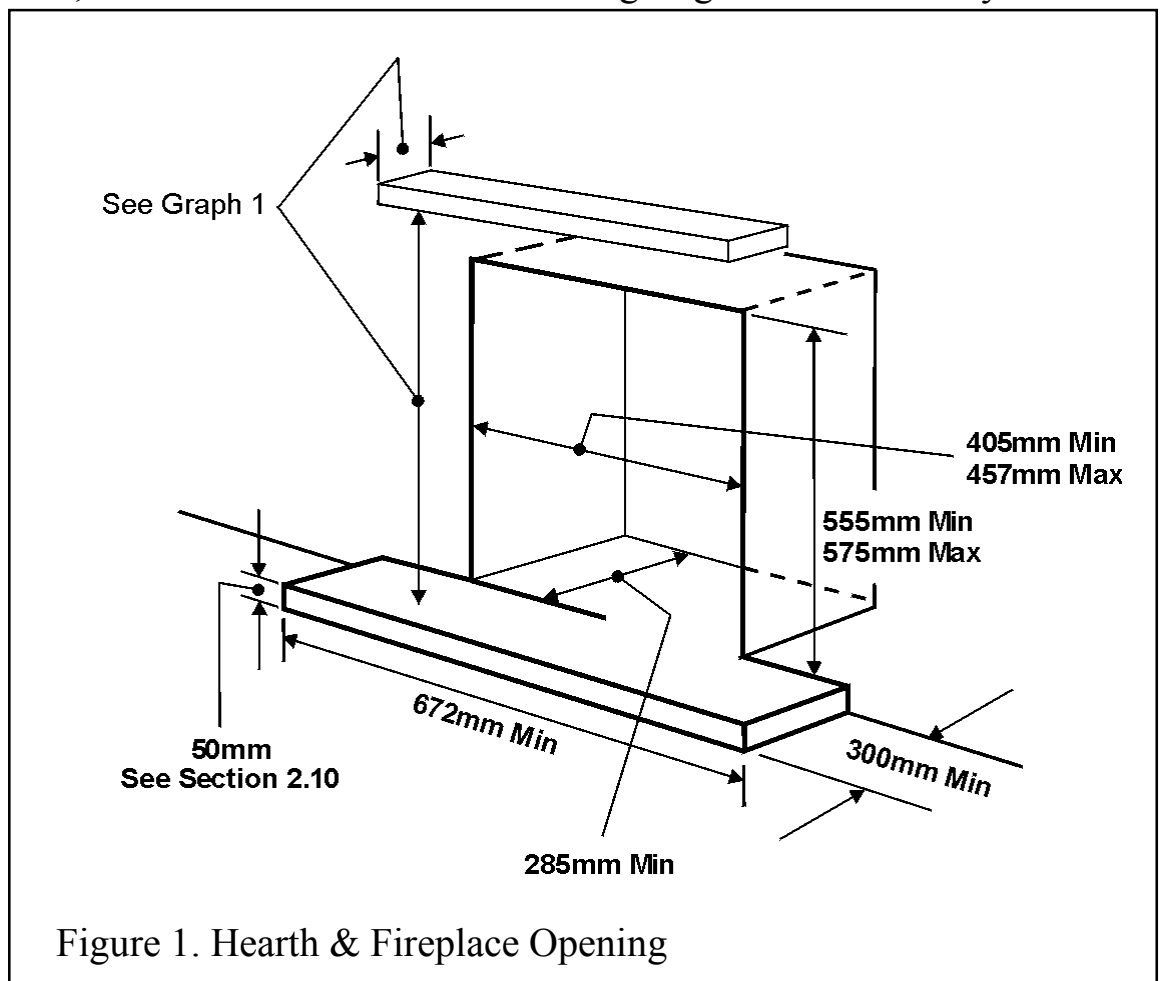

# INSTALLER'S GUIDE

the Environment for Northern Ireland.

In the republic of Ireland the installation must also conform to the relevant parts of:

- a) The current edition of IS 813
- b) All relevant national and local rules in force.

**2.2** In the United Kingdom, as supplied, the appliance can be installed in the following situations: -

**2.2.1** To a fireplace complete with surround and hearth as shown in figure 1 and complying with BS1251 after removal of the fireback and sufficient material behind the fireback

for a debris catchment space. The required fireplace, hearth, debris catchment area and clearance dimensions are shown in figure 1.

### **2.2.1.1** 'Hole-in-the-wall' Installations

- It is recommended that a hearth should be installed as in figure 1.
- If a reduced depth Hearth is fitted, the fire must be installed so that the distance from the base of the fireplace opening in the wall to the finished floor level is at least 85mm. It is recommended that the reduced hearth has a depth from the fixing plane of the fire of 100mm minimum. This is necessary to support the lower front casting.

**2.2.2** To a fireplace incorporating a metal flue box complying with the constructional requirements of the current edition of BS715. The dimensions of the flue box must conform to those shown in figure 2.

A precast concrete or clay flue block system conforming to BS1289 with dimensions as in figure 3. The current versions of BS1289 and BS EN 1806 recommend that there should be an air space or insulation between the flue blocks and the plaster because heat transfer may cause cracking on directly plastered flues. However, generally this

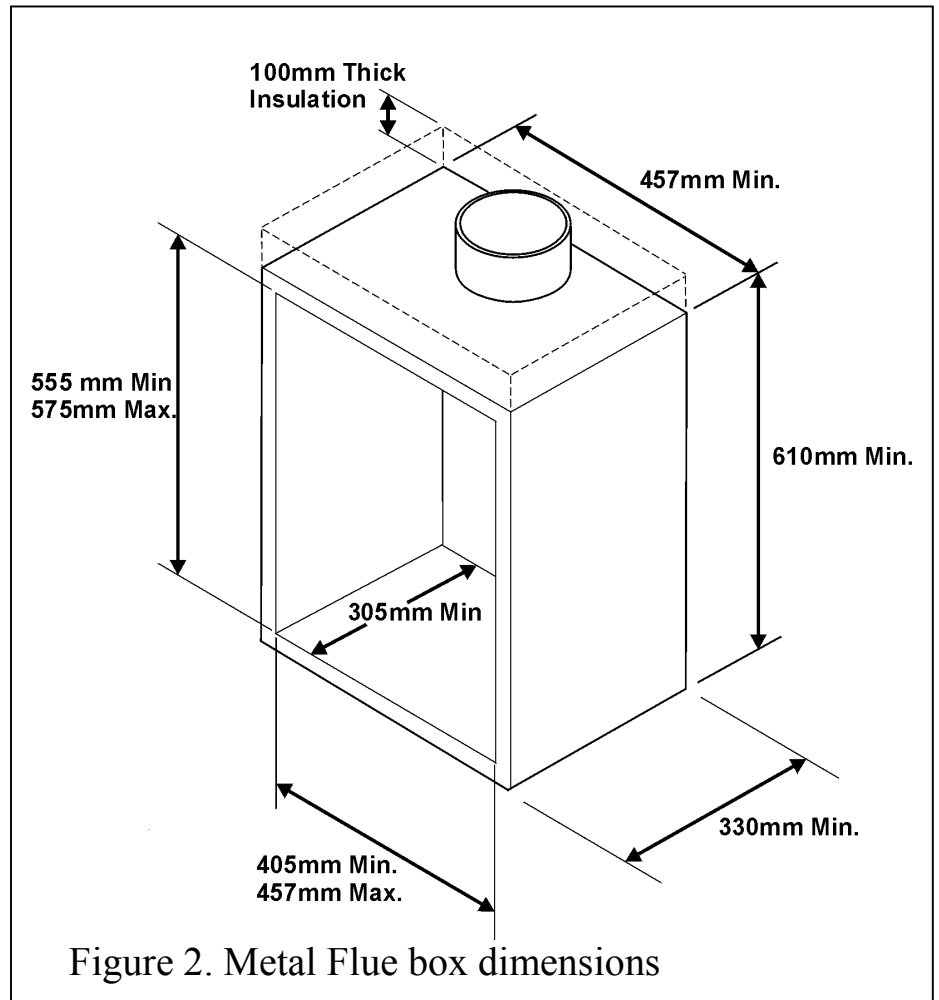

# INSTALLER'S GUIDE

appliance is suitable for installations under all circumstances unless there is a history of cracking problems. Remember that faults such as cracking may be caused by poorly built and restrictive flues, e.g. mortar extrusions, too many bends, flue heights below three metres, restrictive terminations etc.

**2.2.3** If the fireplace opening is greater than the acceptable dimensions given in this guide, do not use the back of a fire surround or marble to reduce the opening. This may cause cracking of the surround back or marble.

**2.4** Suitable flues and minimum flue sizes are as follows: -

*It should be noted that, as with many appliances, sharp bends or horizontal runs in metal flues at the top of the system can be a cause of problems in these types of installation.*

- 225mm x 225mm conventional brick flue.
- 175mm diameter lined brick or stone flue.
- 200mm diameter factory made insulated flue manufactured to BS4543.
- 175mm diameter flue pipe. See BS6461 Part 1 for suitable materials.
- Single wall, twin wall or flexible flue liner with a minimum diameter of 125mm. The materials to be used are stainless steel or aluminium as specified in BS715. The liner must be sealed to the surrounding area above the fireplace opening and to the top of the chimney. An approved terminal must be fitted.
- A properly constructed precast concrete or clay flue system conforming to BS1289 or BS EN 1806. This system is only suitable if the conditions stated in section 2.2.2 are met.

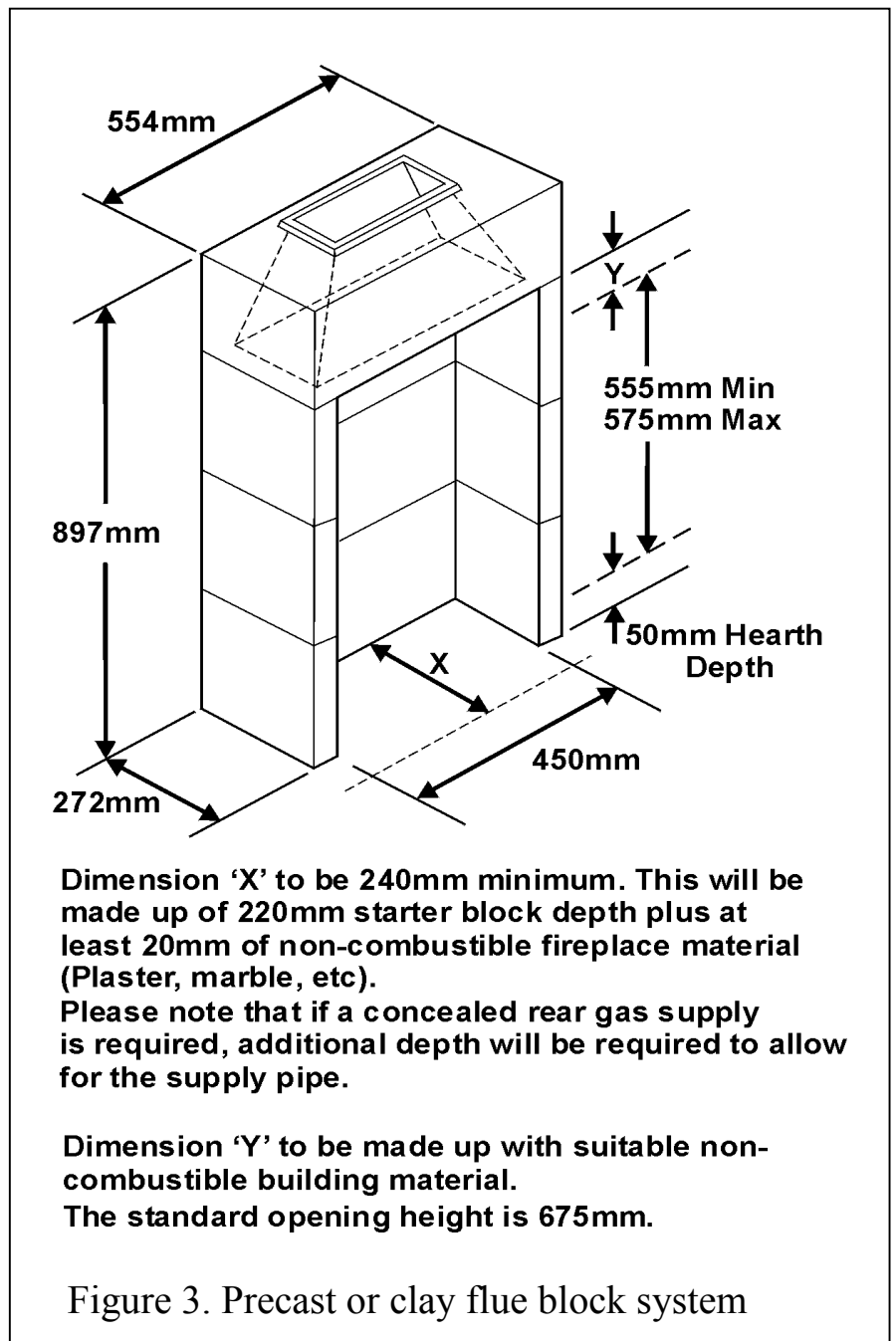



# INSTALLER'S GUIDE

- 2.5** The flue must conform to BS 5440: Part 1 in design and installation. The flue, measured from the bottom of the fireplace opening to the bottom of the terminal, shall be not less than 3m in actual vertical height. When calculated in accordance with BS 5440: Part 1 Annex A, the minimum **equivalent** height of the flue shall be 2.0m of 125mm-dia. flue pipe.
- 2.6** The flue must not be used for any other appliance or application.
- 2.7** Any chimney damper or restrictor should be removed. If removal is not possible, they must be secured in the open position.
- 2.8** If the appliance is intended to be installed to a chimney that was previously used for solid fuel, the flue must be swept clean prior to installation. All flues should be inspected for soundness and freedom from blockages.
- 2.9** If the fireplace opening is an underfloor draught type, it must be sealed to stop any draughts.
- 2.10** The appliance must be mounted behind a non-combustible hearth (N.B. conglomerate marble hearths are considered as non-combustible). The appliance can be fitted to a purpose made proprietary class "O"-150°C surround. The hearth material must be at least 12mm thick. The periphery of the hearth (or fender) should be at least 50mm above floor level to discourage the placing of carpets or rugs over it. The surface of the hearth must be sufficiently flat to enable the bottom of the front surround and the bottom front cover to be aligned horizontally. Any excessive unevenness (uneven tiles, Cotswold stone, etc.) should be rectified. The appliance must not stand on combustible materials or carpets.
- 2.11** The front face of the fireplace should be reasonably flat over the area covered by the hotbox top and side flange seals to ensure good sealing. These faces should be made good if necessary. The fireplace floor should be reasonably flat to ensure that a good seal with the hotbox can be made.

# INSTALLER'S GUIDE

**2.12** The minimum height from the top surface of the hearth to the underside of any shelf made from wood or other combustible materials is shown in graph 1.

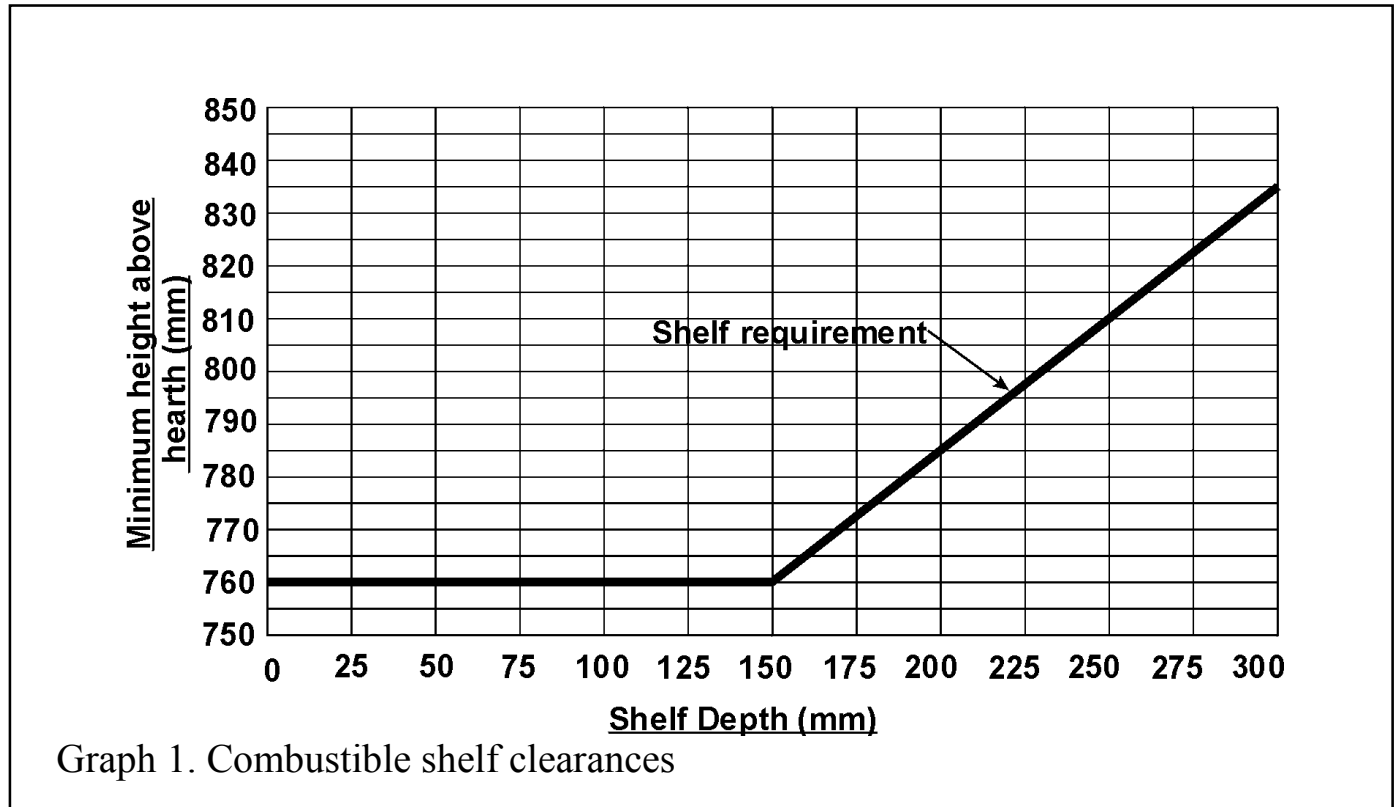

**2.13** Note that soft wall coverings (e.g. embossed vinyl, etc.) are easily affected by heat. They may scorch or become discoloured when close to a heating appliance. Please bear this in mind when installing.

**2.14** This appliance must not be installed in any room that contains a bath or shower or where steam is regularly present.

**2.15** An extractor fan may only be used in the same room as this appliance, or in any area from which ventilation for the appliance is taken, if it does not affect the safe performance of the appliance. Note the spillage test requirements detailed further on in this manual. If the fan is likely to affect the appliance, the appliance must not be installed unless the fan is permanently disconnected.

**2.16** In the United Kingdom (GB) no special ventilation bricks or vents are normally required in the room for this appliance. In the Republic of Ireland (IE) permanent ventilation must comply with the regulations currently in force.

# INSTALLER'S GUIDE

**2.17** Propane gas appliances must not be installed in a room that is built entirely below ground level (See BS 5871 Part 2).

**2.18** If the appliance is to be fitted against a wall with combustible cladding, the cladding must be removed from the area covered by the outer surround. The cladding must also not touch the surround. (See figure 4). We suggest that the actual surround is used as a template to mark the area for combustible cladding removal and that this area is increased by at least 2mm all round.

**2.19** The minimum allowable distance from the outside of the appliance case to a corner wall having combustible material or any other combustible surface which projects beyond the front of the appliance is shown in figure 5. A 10mm access clearance from a non-combustible surface is necessary at the left side. See figure 5.

**2.20** Proprietary terminals must comply with BS 715 or BS 1289. Any terminal or termination must be positioned in accordance with BS 5440 Part 1 to ensure that the products of combustion can be safely dispersed into the outside atmosphere. Where the appliance is connected to an unlined brick chimney it is generally unnecessary for the chimney pot to be replaced or for a terminal to be fitted unless the flue has a diameter smaller than 170mm.

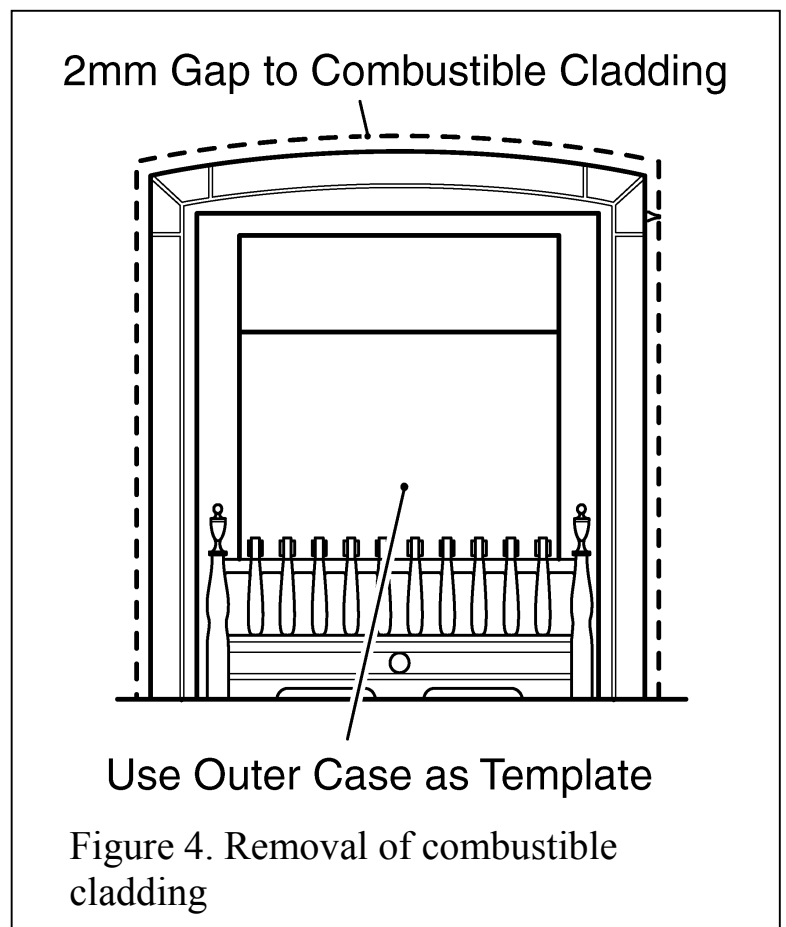

# INSTALLER'S GUIDE

108mm minimum mandatory clearance to combustible surface projecting beyond front of appliance. For access purposes a 10mm clearance is recommended to non-combustible surfaces.

108mm minimum mandatory clearance to combustible surface projecting beyond front of appliance. This is also the recommended clearance for access purposes.

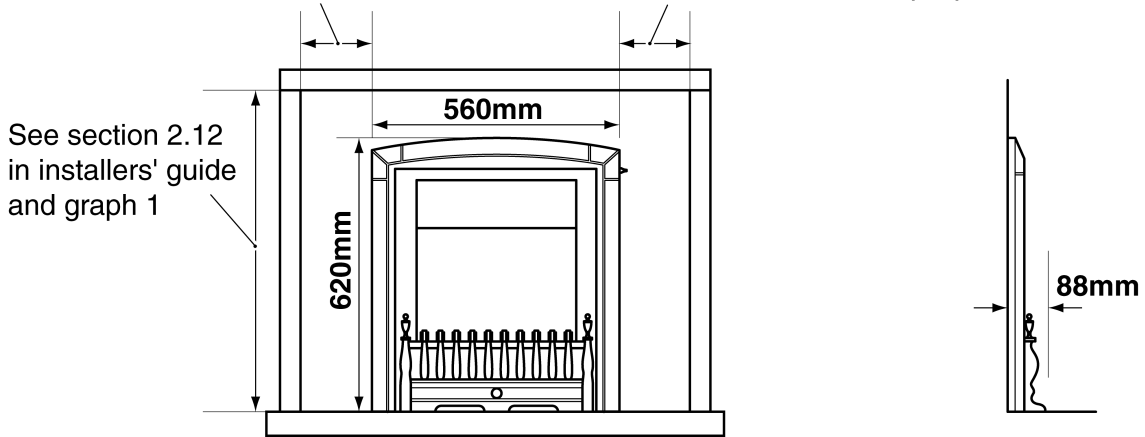

Figure 5 Continued. Appliance dimensions

## 3 PACK CONTENTS

The items required for this appliance are packed in two sections.

Section 1 - Fire Unit contains:

- 1 Burner & Hotbox Unit
- 1 Burner front baffle
- 1 Nut & olive for 8mm inlet pipe
- 1 Flue restrictor plate
- 2 Screws (For flue restrictor)
- 2 Screws (For Fireback spacing brackets)
- 2 Washers (For case hanging)
- 2 Screws (For Rear Ceramic wall support bracket)
- 1 Ceramic back wall
- 1 Pair of ceramic side walls
- 1 Left Hand Front coal
- 1 Right Hand Front coal
- 1 Main coal bed
- 1 Pack of 12 loose coals identified by the letters 'A' to 'L'
- 2 Small "U" seals for hotbox side flanges
- 1 Strip of floor sealing tape
- 6 Fibre plugs
- 4 Woodscrews
- 2 Fire retaining cables

# INSTALLER'S GUIDE

- 2 Cable clamps
- 4 Eyebolts
- 1 Rubber grommet
- 1 Knurled shouldered screw for control linkage fixing
- 1 PP3 Battery
- 1 Smoke match tube
- 2 Fireback spacing brackets
- 1 Rear Ceramic wall support bracket
- 1 Length of self adhesive foam seal
- 1 Literature pack
- 1 Fireslide slider control
- 2 Taptite screws

## Section 2 - Fire Front contains:

- 1 Fire front surround.
- 1 Firefront casting
- 1 Bottom front cover casting

Carefully remove all the contents. Take special care in handling the ceramic walls and the coals. Check that all the listed parts are present and in good condition.

# INSTALLER'S GUIDE

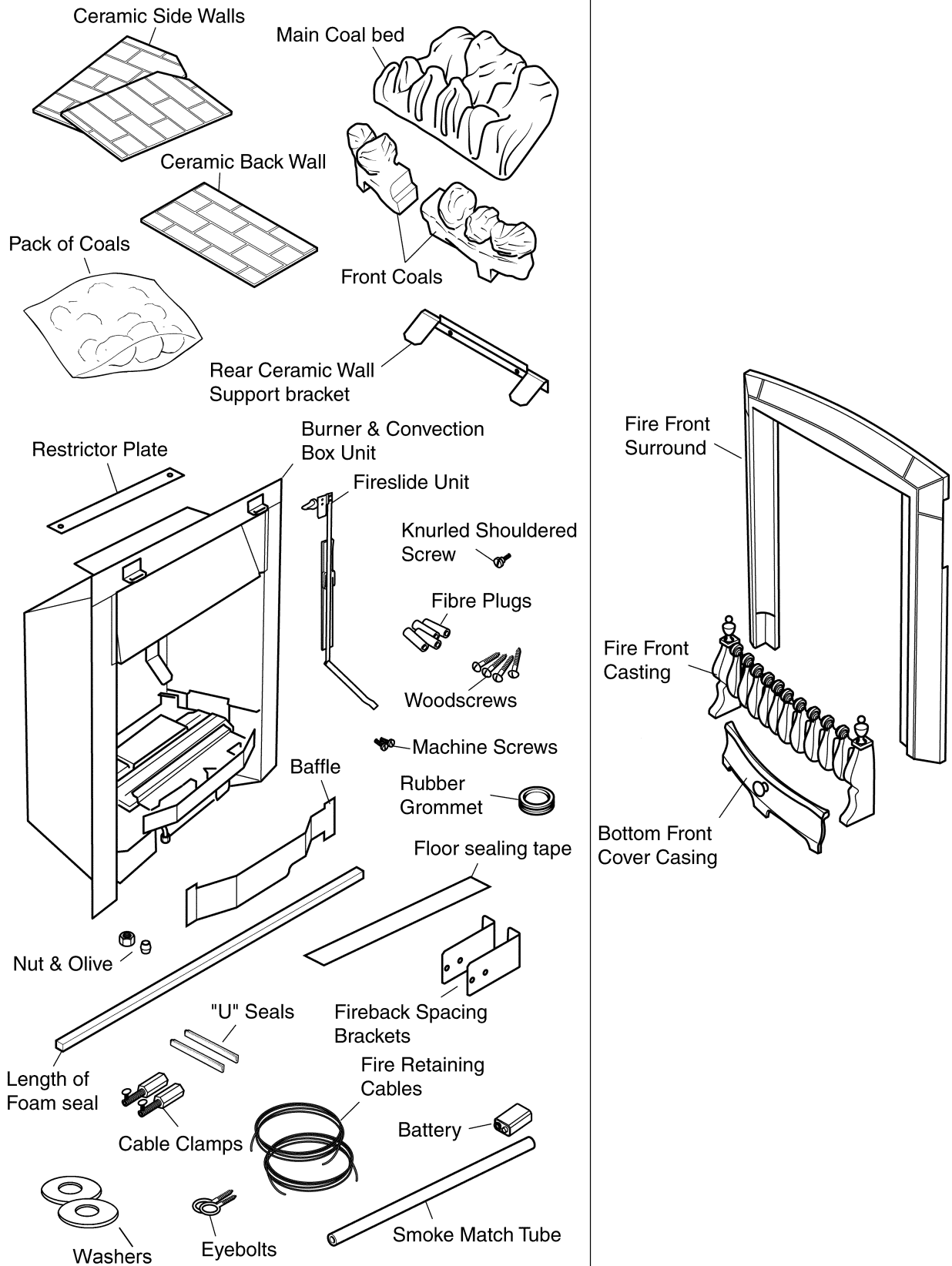

Figure 6. Pack contents

## 4 FIREPLACE CHECK

### 4.1

#### 4.1.1 Fireplace size

The fireplace must comply with the requirements described in section 2.2. This will probably entail removing the fireback and infill material behind the fireback. The debris catchment area shown in figure 7 must be kept clear of obstructions.

#### 4.1.2 Fireplace general condition

The fireplace floor should be reasonably flat to ensure that the hotbox can be installed without it rocking and so

that a good seal can be made at the bottom front of the box. The front face of the fireplace should be reasonably flat over the area covered by the hotbox top and side flange seals to ensure good sealing. These faces should be made good if necessary. If the appliance is to be fitted against a wall with combustible cladding, the cladding must be removed from the area covered by the outer surround. The cladding must also not touch the surround. (See figure 4). We suggest that the actual surround is used as a template to mark the area for combustible cladding removal and that this area is increased by at least 2mm all round.

#### 4.1.3 Soundness for appliance attachment

Two primary methods of retaining the appliance are provided: -

- 1) By fixing to the fireplace front surround.
- 2) Using concealed tension cables fixed to the rear of the fireplace opening together with secondary fixing to the fireplace floor.

The methods are detailed in section 8 of this manual. Before selecting the retention method, consult with the customer. Method 2 is provided for instances where drilling holes in the front surface of the fireplace surround is unacceptable to the customer or otherwise impractical. *N.B. It is unwise to attempt to drill into marble without the proper tools and equipment.*

If method 1 is chosen, make sure that the front surround area is sound enough to take the Fibre plugs and woodscrews. If necessary, make sound with a suitable cement.

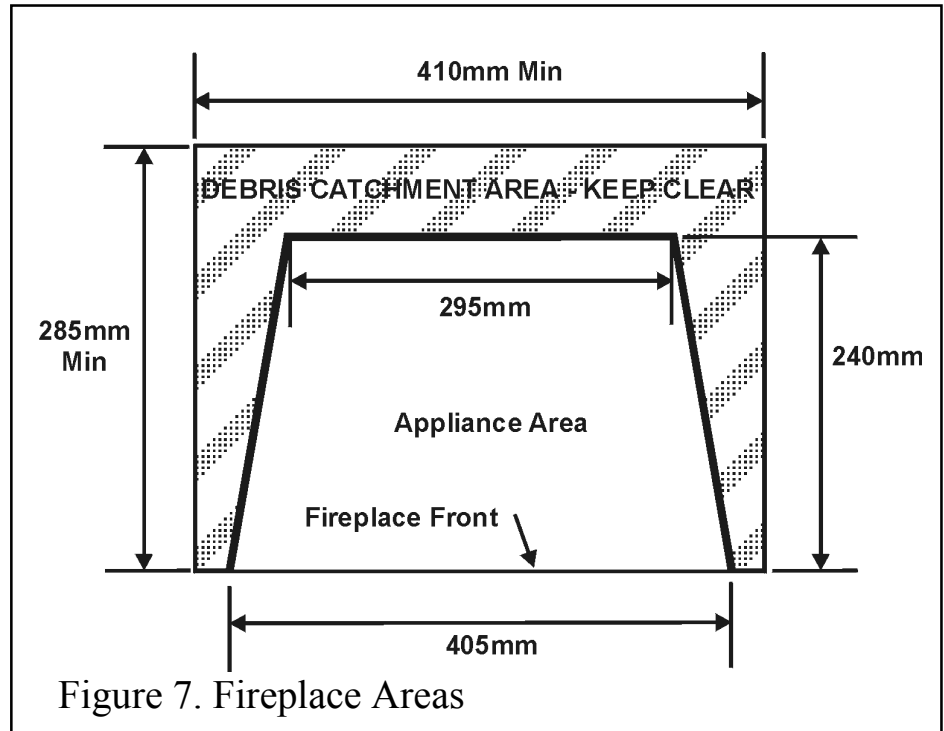

# INSTALLER'S GUIDE

If method 2 is chosen, make sure that the areas at the back and towards the centre of the fireplace floor are sound enough to take the eyebolts and screws. If these areas have deteriorated due to prolonged use, they should be made sound with a suitable cement.

## 4.1.3 Installations using a metal flue box

The whole of the top surface of the metal flue box must be covered with a 100mm layer of mineral wool or equivalent insulation. (See figure 2).

## **4.2 Fireplace Flue Pull**

Close all doors and windows in the room in which the appliance is to be installed. After confirming with a match that smoke is drawn into the flue, light a 13 gram smoke pellet and check that there is a definite flow through the flue. Verify outside that the smoke exits from one terminal only and that the termination is suitable. Observe, where possible, upstairs rooms and loft spaces for signs of escaping smoke indicating a defective flue. If there is not a definite flow warm the flue for a few minutes and repeat the smoke pellet test. If there is still no definite flow the flue may need remedial work – **Do not fit the appliance until there is a definite flow through the flue.**



# INSTALLER'S GUIDE

## 5 IGNITION CHECK

Before attempting to install, it is worth checking that the electronic ignition system performs satisfactorily.

- Fit the battery to the ignition block located below the burner tray at the left side (see figure 8). The positive terminal (+) is to the bottom as you insert.

Rotate the control pivot bracket as far as it will go. This should close the ignition circuit. Sparks should be seen tracking from the electrode pin to the thermocouple tip. See figure 9.

- If there are no sparks make the following checks.
  - a.* Check condition of battery and that it is correctly fitted.
  - b.* Check spark gap between electrode wire and thermocouple tip. See figure 10.
  - c.* If a & b are satisfactory, check the ignition circuit and components - see the servicing section in this manual.

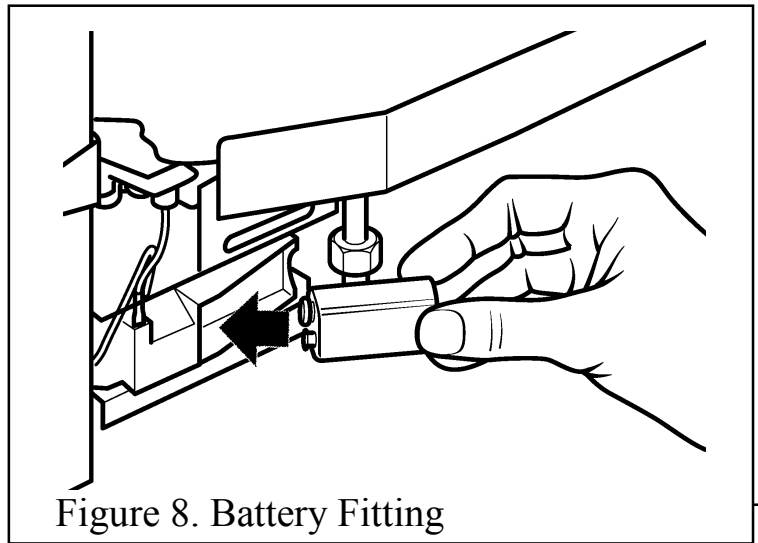

Figure 8. Battery Fitting

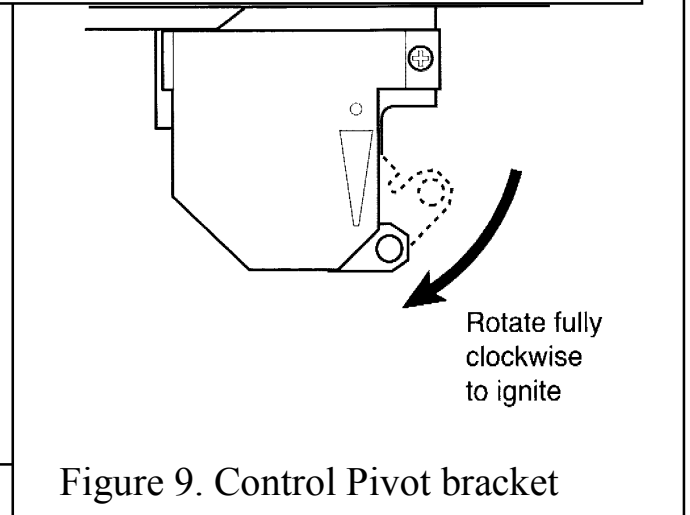

Figure 9. Control Pivot bracket

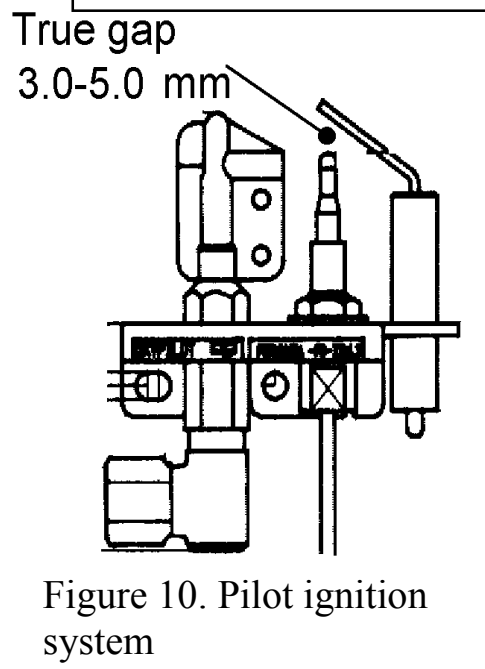

Figure 10. Pilot ignition system

## 6 GAS SUPPLY CONNECTION

A nut and olive are provided for an 8mm pipe inlet connection to the elbow at the bottom front of the appliance. The elbow can be rotated to allow a connection from any direction. The elbow includes a valve for isolating the gas supply.

The supply pipe must be rigid material. Flexible pipe must not be used.

### 6.1 Concealed Supply Pipe Connection

If a concealed connection from inside the fireplace is required then, **before the appliance is fitted into the fireplace** it will be necessary to extend the supply line so that it will project through the chosen removable circular panel at the back of the hotbox and run to the elbow at the front. The pipe run from the supply line up to the rear opening in the hotbox must be kept away from the area which will be taken by the hotbox when it is installed (See figure 7).

Note that the centre of the appliance inlet elbow is 25mm above the fireplace floor. The inlet elbow should be removed from the appliance and fitted to the supply pipe at this stage.

## 7 PREPARING APPLIANCE FOR INSTALLATION

### IMPORTANT

Before continuing with the installation of this gas fire the aeration setting on the burner must be checked. This has been factory set. See section 16 (Servicing and parts replacement).

4. Detach the burner unit from the hotbox by removing two screws - See figure 11. Lift the burner unit clear.
5. Fit the two "U" section seals to the bottom edges of the hotbox side flanges. See figure 12.
6. For concealed connection only: There are two removable circular panels at the rear of the hotbox. Decide which one of these is to be used for rear entry. Using a suitable tool apply pressure to the centre of the removable circular panel. There is a grommet in the installation kit supplied with the fire. Fit this into the hole. Pierce the grommet to allow the pipe to pass through it. The grommet should envelop the pipe. If the hole is larger than the pipe, seal it with tape. **Do not pierce the grommet unless the supply pipe is to pass through it.**
7. The appliance is supplied with two fireback spacers. **Do not fit the fireback spacers if the fire is to be installed into a precast or clay flue block system as in section 2.2.2.** These should extend backwards to ensure sufficient clearance from the back of the fireplace. Remove the label and retaining screws from the rear sides of the hotbox. Position the fireback spacer as shown

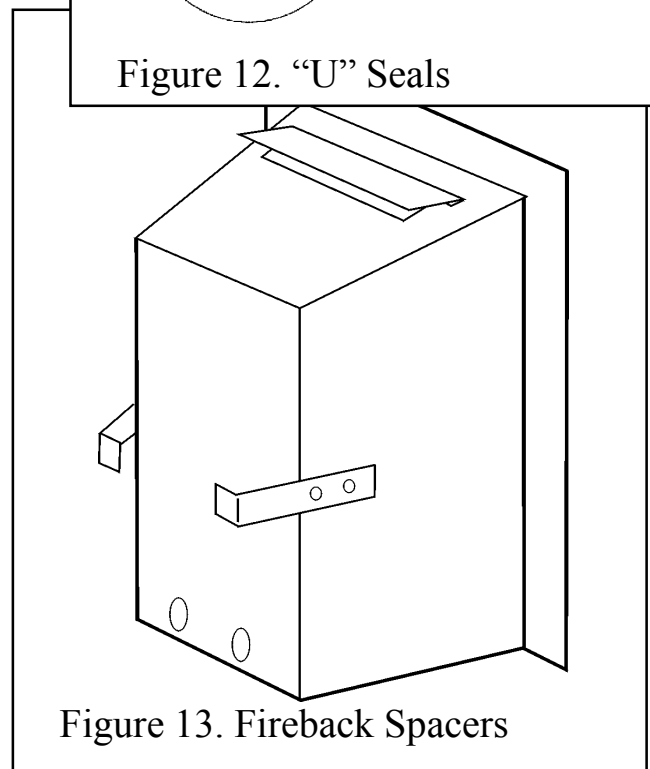
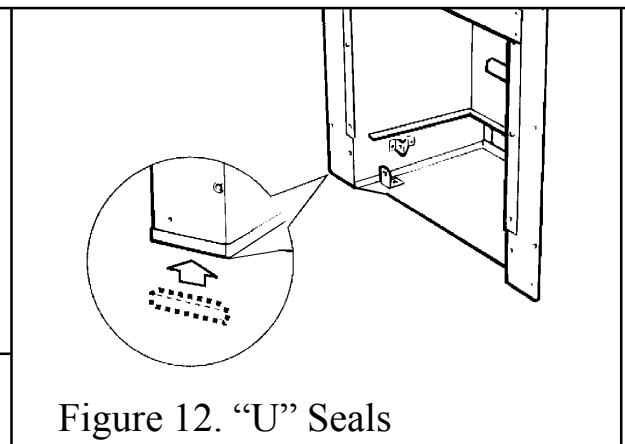
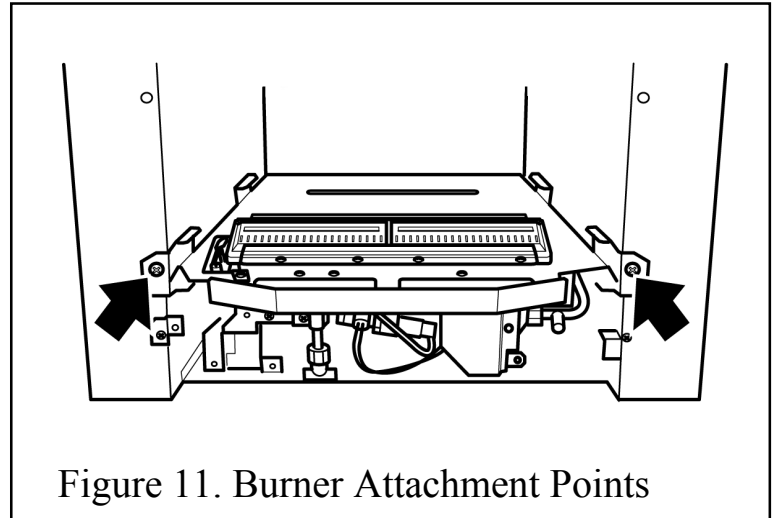

# INSTALLER'S GUIDE

in figure 13. Secure the fireback spacers using the screws removed previously and the two supplied with the fire.

**8.** This appliance is supplied with a flue restrictor for use where the flue draught is excessive. The restrictor must NOT be fitted where a precast flue or a flue liner is used. For all other installations the restrictor should be fitted. There may however, be certain exceptional circumstances where fitting the restrictor causes the fire to fail the spillage test. In such cases the restrictor will have to be removed. After removal conduct the spillage check again. The restrictor is packed loose with the appliance and is fixed with two screws. See figure 14.

**9.** There is a length of self adhesive foam seal supplied with the fire. This will need to be fitted to the outer rear edges of the side and top flanges of the hotbox. Cut a 485mm length of foam seal. Be careful not to stretch the seal when measuring. Remove the protective backing from the foam seal and fit this to the rear of the top flange (See figure 15). Cut two 580mm lengths. Fit these to the rear outer edges of the side flanges. Ensure that there is no gap between the foam seals where they meet at the top flange (See figure 15).

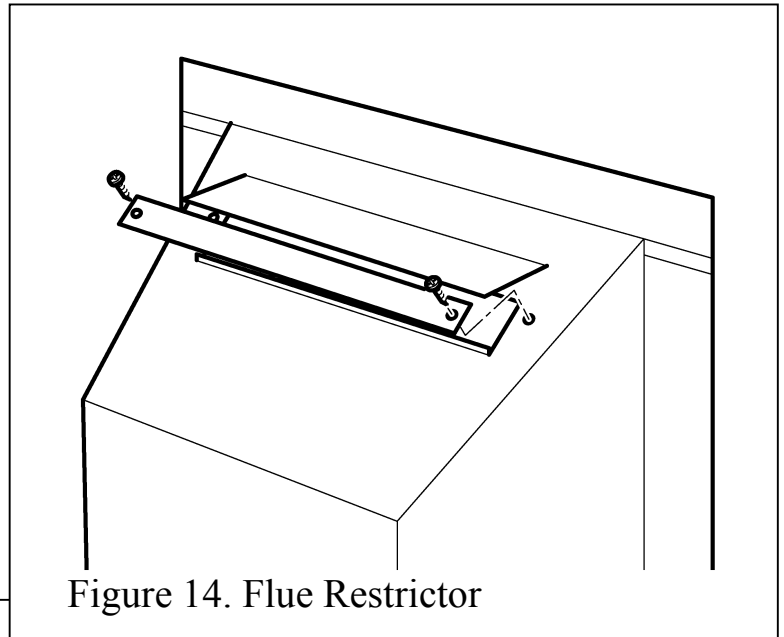

Figure 14. Flue Restrictor

The Foam Seal should touch at this point.  
Ensure that there is no gap between the seals

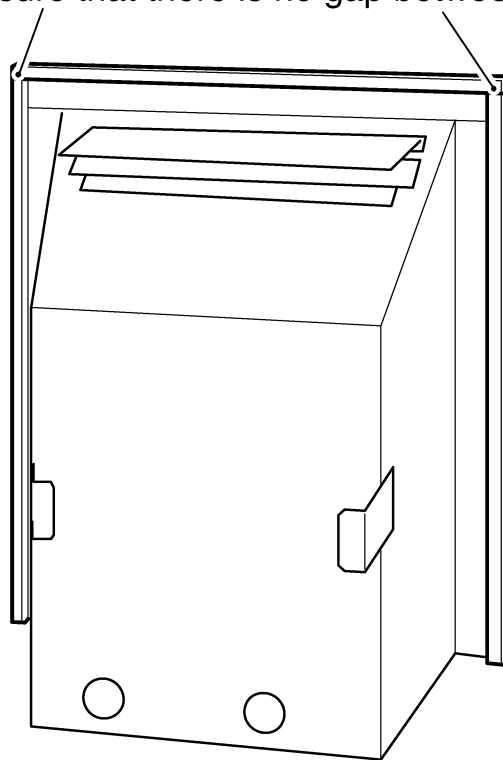

Figure 15. Fitting the foam seal

## 8 HOTBOX INSTALLATION

### 8.1 Method 1 - Front Fixing to Fireplace Surround

1. Make sure that the fireplace front surround area is sound enough to take the rawlplugs and woodscrews. If necessary, make sound with a suitable cement.
2. Place the hotbox centrally in the fireplace in the position in which it is to be permanently installed. If a concealed connection is being used, insert the hotbox into the fireplace feeding the supply pipe through the pierced hole in the rear seal.
3. Mark the fireplace front surround through the four fixing holes in the side flanges of the hotbox. See figure 16.
4. Remove the hotbox. Drill four holes in the fireplace front surround at the marked positions using a no.12 masonry drill.
5. Insert a rawlplug into each hole.
6. Place the hotbox back in position in the fireplace.
7. Fit a woodscrew through each hole in the hotbox flanges and tighten to seal the box to the fireplace surround.

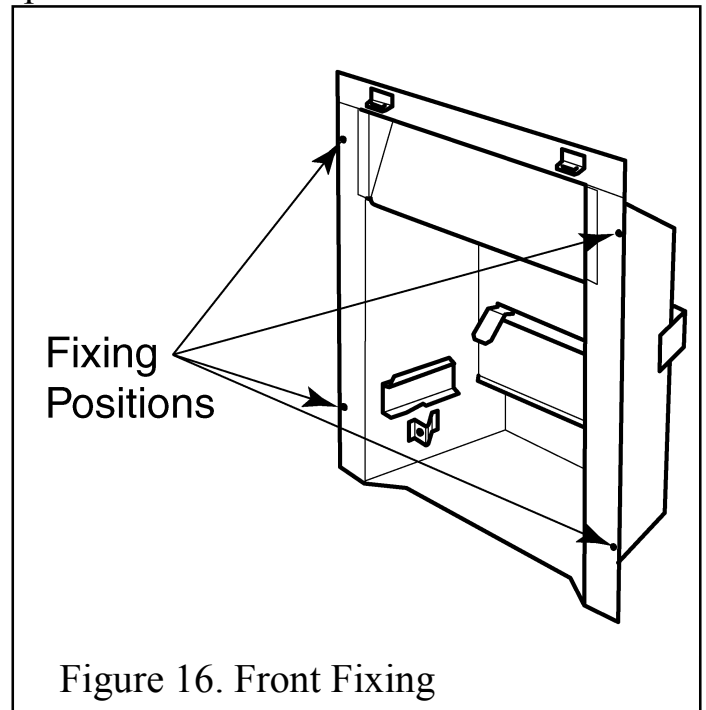

Figure 16. Front Fixing

## 8.2 Method 2 - Cable Retention and Floor Fixing.

1. Make sure that the relevant areas at the fireplace back or floor are sound enough to take the eyebolts and screws. If these areas have deteriorated due to prolonged use they should be made sound with a suitable cement.

2. Drill four holes in the rear wall or floor of the fireplace for the eyebolt plugs. The holes should be drilled within the range of positions shown in figure 17 using a no.12 masonry drill. The holes should be equidistant each side of the centre line of the fireplace to ensure that the appliance finishes centrally in the opening when tension is applied to the cables.

3. Insert a fibre plug into each hole. Use the fibre plugs supplied with this appliance - **Never use plastic plugs instead of the fibre plugs supplied.** Screw the eyebolts into the plugs. Make sure that the bolts are secure.

4. Place the convection box unit close to the fireplace but allow sufficient access into the fireplace opening so that the cables can be threaded through the eyebolts and returned through the back of the convection box. If a concealed connection is being used, insert the convection box into the fireplace feeding the supply pipe through the pierced hole in the rear grommet.

5. The convection box has two holes at each side of the convected air opening. Insert one end of each cable (one cable each side) from the back through the lower of the two holes and return the end through the upper of the holes. See figure 18. Give the cables a pull so that they grip against the convection box flanges.

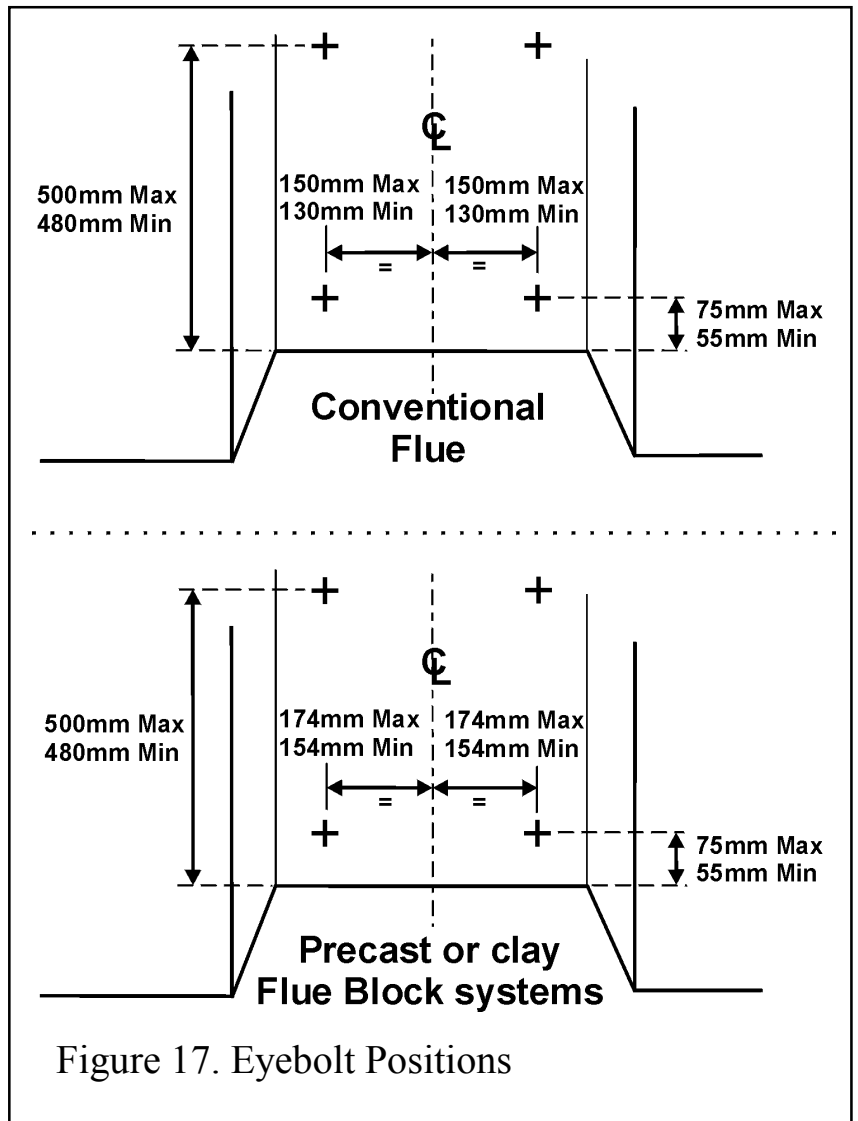

Figure 17. Eyebolt Positions

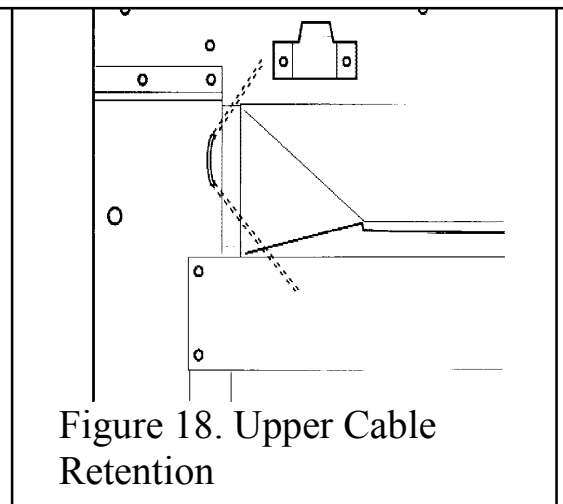

Figure 18. Upper Cable Retention

# INSTALLER'S GUIDE

6. Thread the cables through the eyebolts. Return the cables through the holes near the bottom of the convection box back panel, (**For precast or clay block flue systems return the cables through the slotted holes in the side of the convection box**), and through the “V” shaped brackets near the bottom front sides of the convection box - See figure 19.

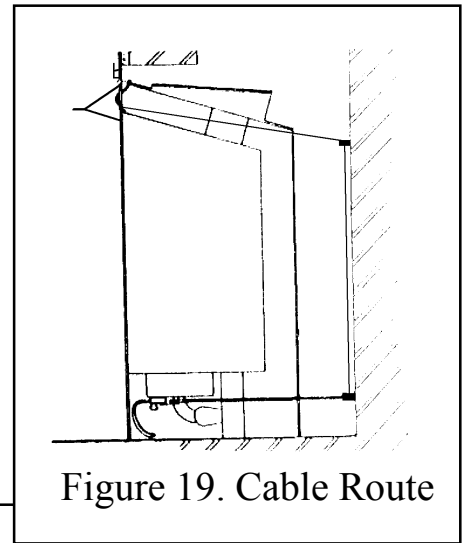

Figure 19. Cable Route

7. Place the convection box fully back into the fireplace opening so that it is sealed against the fireplace front surround.

8. Drill a hole into the fireplace floor through each of the two holes in the base of the convection box using a no.12 masonry drill. See figure 20.

9. Insert a fibre plug into each hole. Use the rawlplugs supplied with this appliance - **Never use plastic plugs instead of the fibre plugs supplied.** Fit a woodscrew in each plug and tighten.

*Always screw the base into position before applying tension to the cables.*

*This will ensure a tight seal between the top of the convection box and wall*

10. Fit a cable retainer over the bottom end of each cable.

11. Pull each cable taut. Push the cable retainers hard up against the “V” brackets. Tighten the screws in the retainers so that they clamp the cables in position. Apply tension to the cables by turning the hexagonal adjusters by hand. See figure 21.

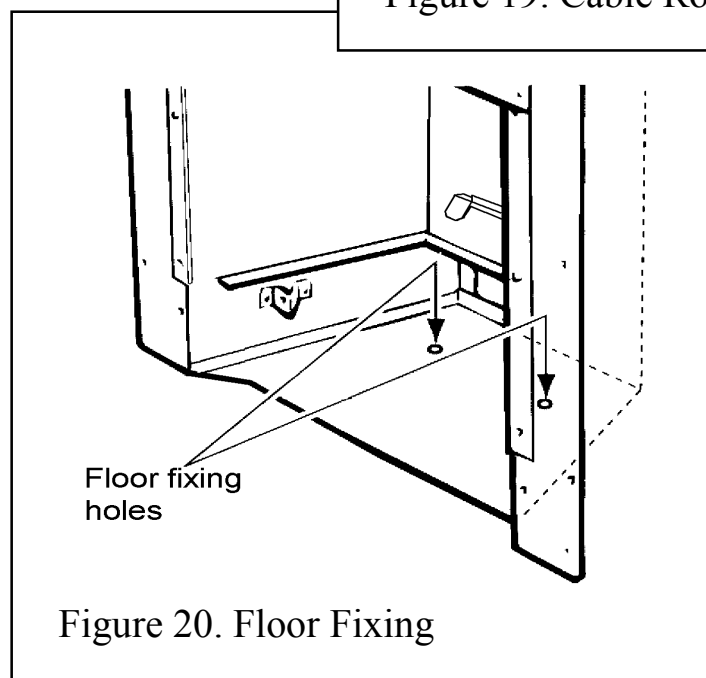

Figure 20. Floor Fixing

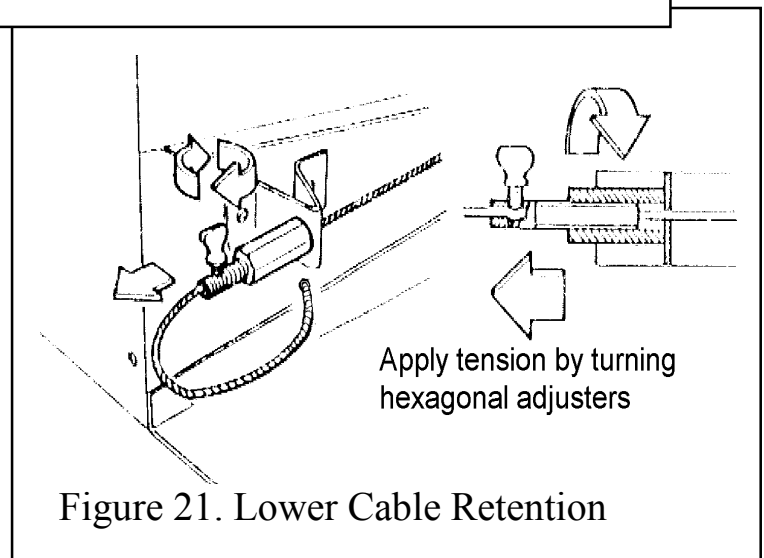

Figure 21. Lower Cable Retention

# INSTALLER'S GUIDE

**12.** Inspect the installation of the convection box against the fireplace surround. If the convection box is aligned squarely and the sealing is satisfactory, fully tighten the cable retainers.

**13.** If the convection box is not correctly aligned, release the tension on the cables by slackening the screws and turning the hexagonal adjusters fully anticlockwise. The convection box should then automatically realign itself. Pull each cable taut again and push the cable retainers back against the "V" brackets. Again, tighten the screws in the retainers and apply tension to the cables by turning the hexagonal adjusters clockwise as far as possible.

**14.** Underneath the 'V' shaped brackets is a hole. Feed the free length of the cables into these holes so that they are available to allow easy removal and refitting of the appliance during subsequent service calls. ***Do not cut off the free lengths of cable***

## **8.3 Sealing Floor Front - All installations**

Using the floor sealing tape supplied, seal the bottom of the convection box to the fireplace and hearth floor - See figure 22.

**Make sure that the whole length of the front edge of the convection box is fully sealed.**

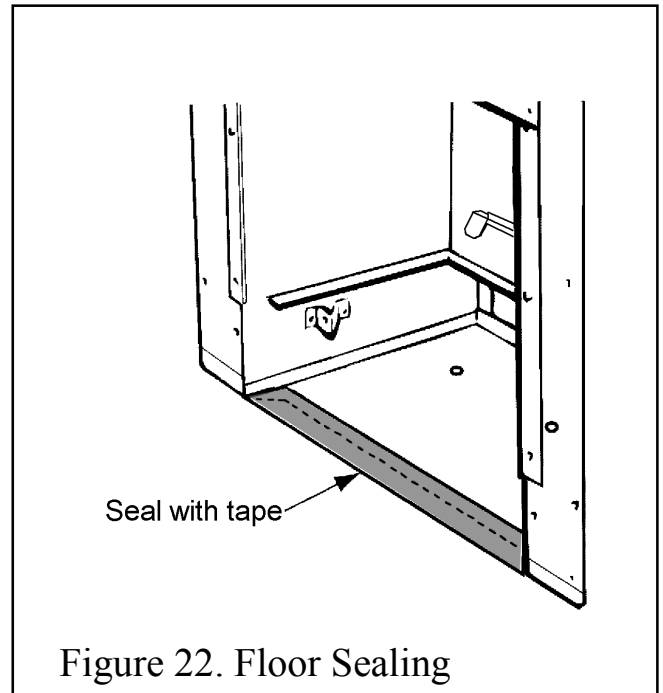

Figure 22. Floor Sealing



## 9 BURNER & SUPPLY PIPE INSTALLATION

### 9.1 Burner & Supply Pipe Installation

1. Refit the burner unit to the hotbox with two screws.
2. Connect the supply line to the appliance.
3. Pressure check the installation pipework for gas soundness. In the United Kingdom check in accordance with the current edition of BS6891. In the Republic of Ireland check in accordance with the rules in force.

### 9.2 Preliminary Burner Checks

Some burner operations can be checked at this stage. Checking now will mean that less disassembly will be required if any problems are found. ***A full check should still be made, however, after final installation.***

1. If closed, open the isolating valve at the inlet elbow.
2. Rotate the control pivot bracket clockwise as far as it will go and hold in this position (See figure 23). This should close the ignition circuit and simultaneously open the gas tap allowing the gas to flow to the pilot. Wait a few seconds while the air is purged. The electronically generated sparks should light the pilot. The pilot should then light the main burner at its low setting. There may be a delay of up to four seconds between the pilot lighting and ignition of the gas at the main burner. This is normal and is due to the time required to fill the main burner compartment with sufficient gas for ignition.

3. When the burner is operating properly, gradually turn the control pivot bracket anti-clockwise. The burner flames should gradually increase until the pivot bracket is nearly at its furthest anti-clockwise rotation. Rotating further until the pivot bracket comes to a stop should then turn the burner and pilot off.

**When the above checks have been completed close the isolating valve on the inlet elbow.**

4. If the above checks are satisfactory, continue with the installation. If not, check the control and ignition circuitry and components as described in the servicing section of this guide.

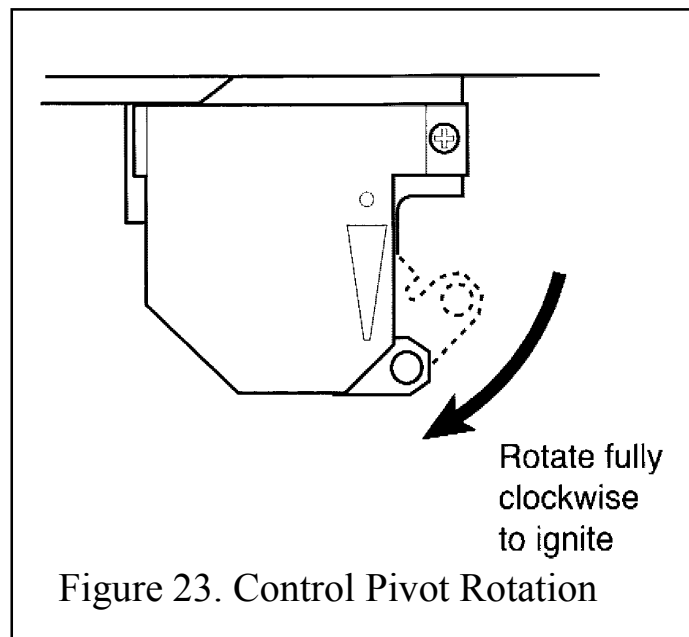

Figure 23. Control Pivot Rotation

# INSTALLER'S GUIDE

## 9.3 Reference Pressure Check

The appliance is pre-set to give the correct heat input at the inlet pressure shown in section 1 of this manual. No adjustment is necessary.

1. Check the burner pressure by fitting a pressure gauge at the test point. The test point is on the pipe situated below the bottom right corner of the burner unit. See figure 24. Check the pressure with the appliance alight and set at maximum output.
2. After checking, turn off the appliance. Remove the pressure gauge and replace the test point sealing screw.
3. Relight the appliance. Turn to the maximum output position and test around the sealing screw for gas soundness with a suitable leak detection fluid.

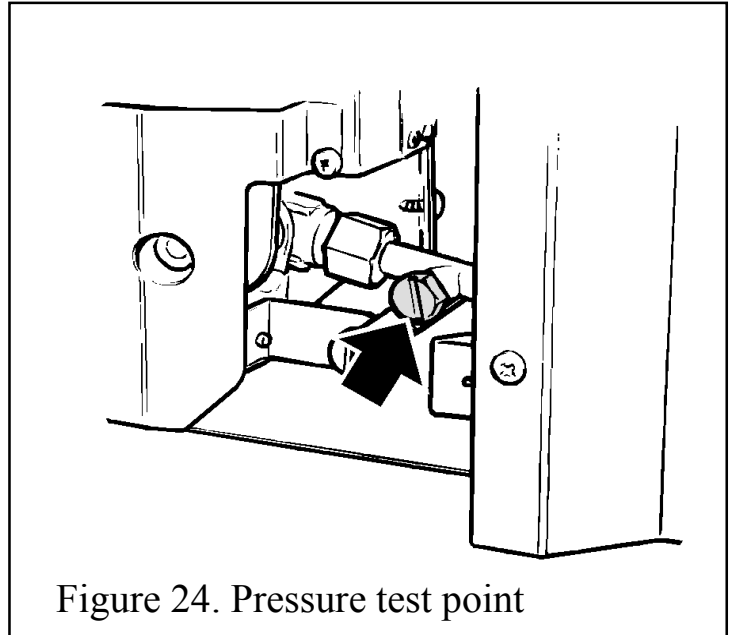

Figure 24. Pressure test point

# INSTALLER'S GUIDE

## 10 CERAMIC WALLS INSTALLATION

1. Fit the rear ceramic wall support bracket to the rear of the hotbox using two screws. The “L” shaped section should be on top with the two side tags underneath. See figure 25.

2. Fit the ceramic rear wall inside the “L” bracket on the back face of the burner compartment. Push the ceramic wall flat against the back face of the burner compartment. See figure 25.

3. Fit the ceramic side walls against the side faces of the burner compartment. The bottom edges of the walls should rest in the ledges at the sides of the firebox. Slide them in from the front and ensure that they touch the rear wall. Be careful not to damage the edges of the side walls. See figure 26.

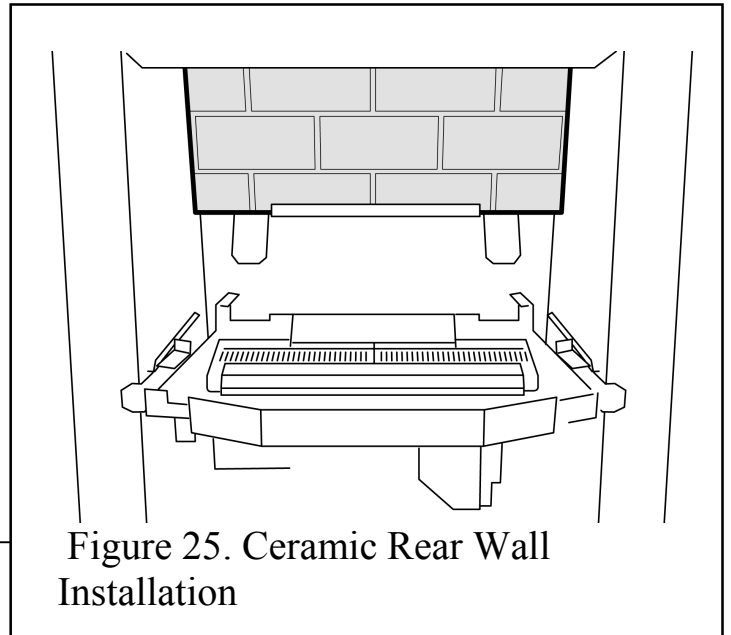

Figure 25. Ceramic Rear Wall Installation

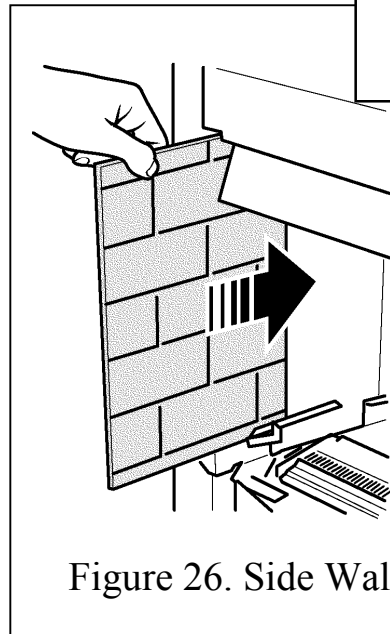
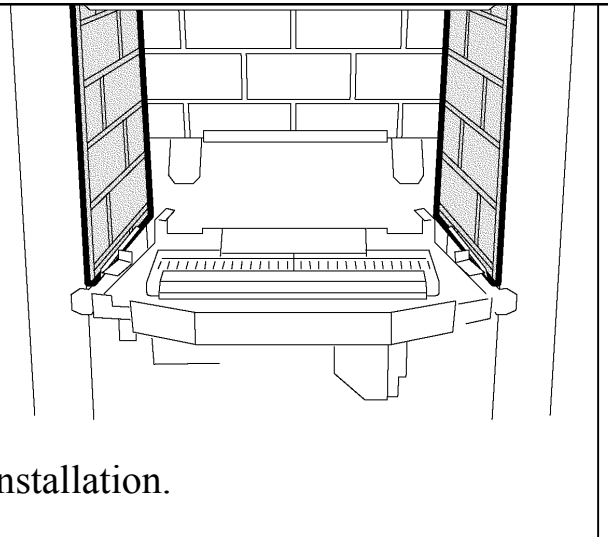

Figure 26. Side Wall Installation.



## 11 FRONT SURROUND & CONTROL LINKAGE INSTALLATION

1. Attach the slider control to the rear of the front surround using 2 Taptite screws (See figure 27). Slide the control button upwards as far as it will go. Make sure that the bottom of the linking bar is higher than the bottom of the front surround.

2. Carefully lift the front surround. **Do not lift it by the control button.**

Place the front surround against the fireplace front surface so that the two retaining plates at the back of the surround are directly above the two upper retaining brackets at the top of the hotbox. Lower the surround unit making sure that the retaining plates locate fully into the brackets on the hotbox (See figure 28). If the inlet pipe runs along the front of the fireplace, the bottom of the casting will have to be swung forwards to clear the pipe while lowering the casting.

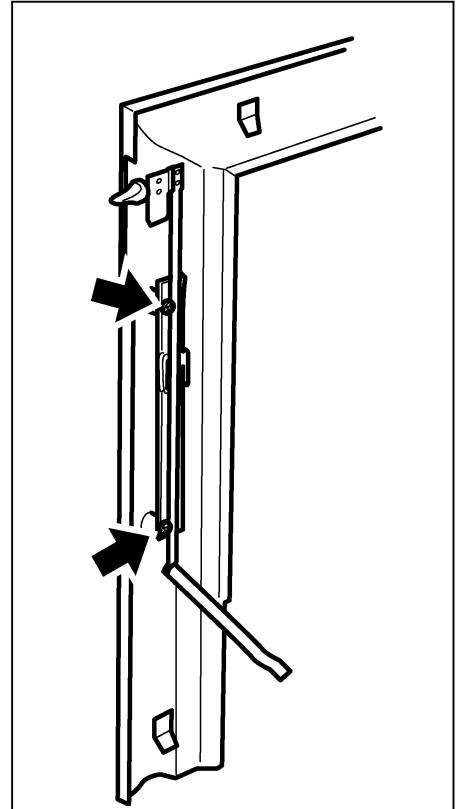

Figure 27. Attach slider to Firefront

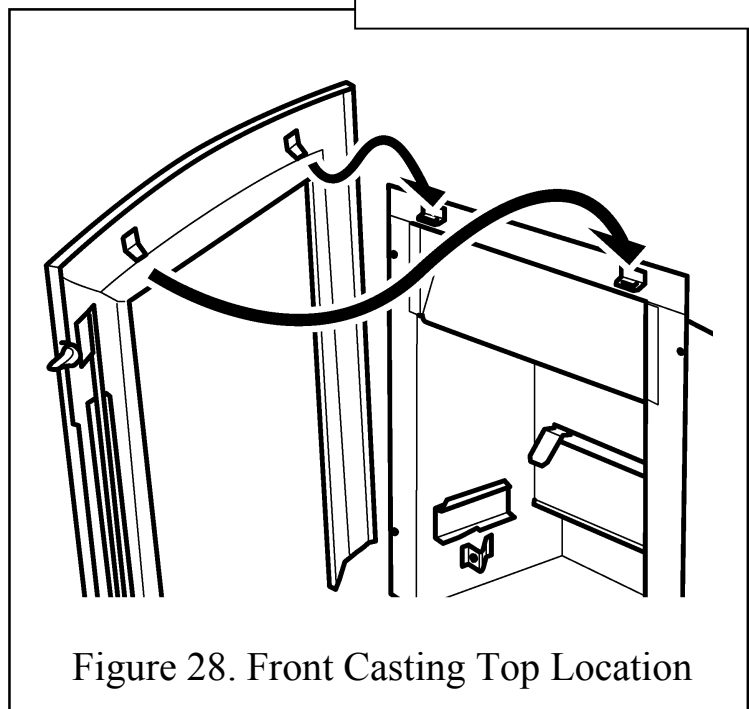

Figure 28. Front Casting Top Location

# INSTALLER'S GUIDE

3. Swing the bottom control linking bar towards the centre of the fire to clear the right side of the surround. Slide the surround unit sideways, if necessary, to align the bottom fixing holes with those in the hotbox. Fix the bottom of the surround unit to the hotbox with two washers and screws (See figure 29).

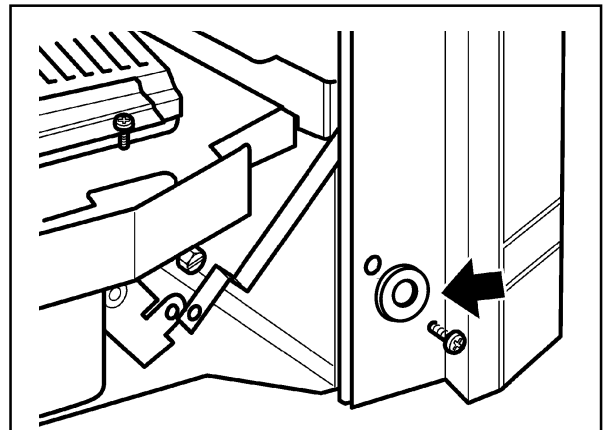

Figure 29. Front Surround Bottom Location

4. Align the hole near the bottom of the control linking bar with that in the control pivot bracket. Join them with the knurled shouldered screw (See figure 30). Make sure that the isolating valve is closed. Slide the control button fully from top to bottom and back to make sure that the slide and pivot mechanisms move smoothly. Note that some resistance should be felt when the slide button reaches the “burner fully on” position.

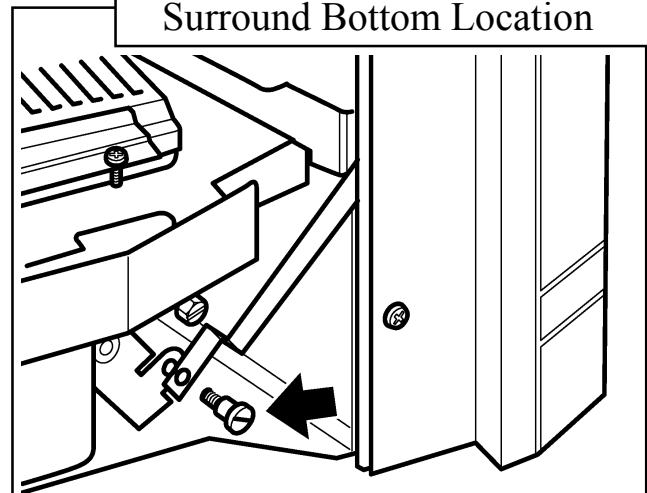

Figure 30. Control Bar & Pivot Bracket

5. Fit the burner baffle to the front flanges of the burner. To do this, place the baffle against the front flanges of the burner and lower into position. The return edges on the rear of the baffle should slot over the front flanges of the burner (See

figure 31).

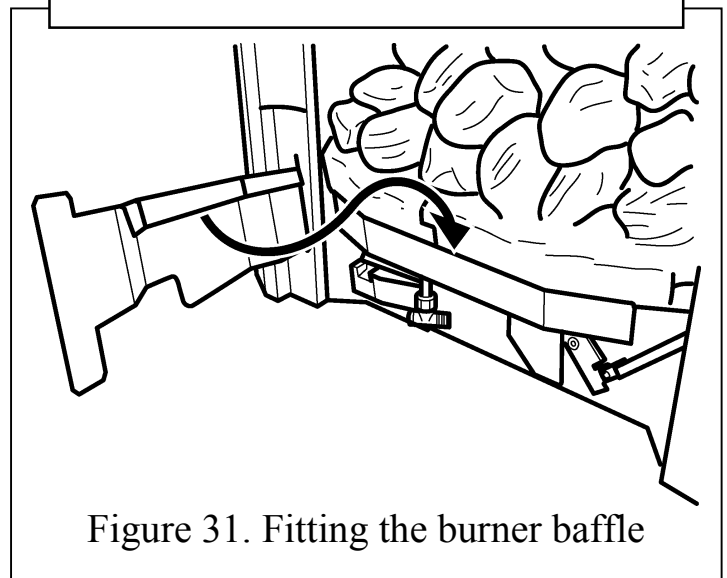

Figure 31. Fitting the burner baffle

## 12 CERAMIC COALS INSTALLATION

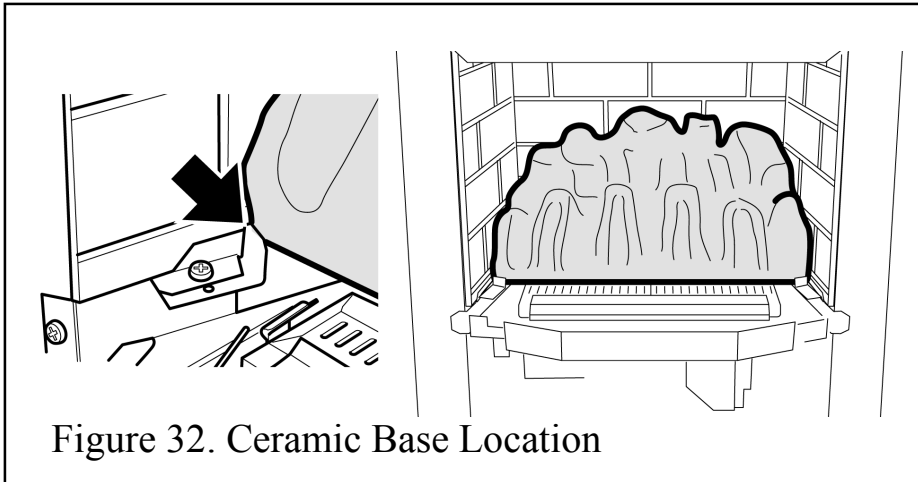

Figure 32. Ceramic Base Location

1. Place the ceramic base coal in the burner compartment. The bottom rear face of the coal should rest on the angled ledges at the back of the burner compartment. The bottom front edges of the coal base should locate against the left and right hand side brackets. (See figure 32).

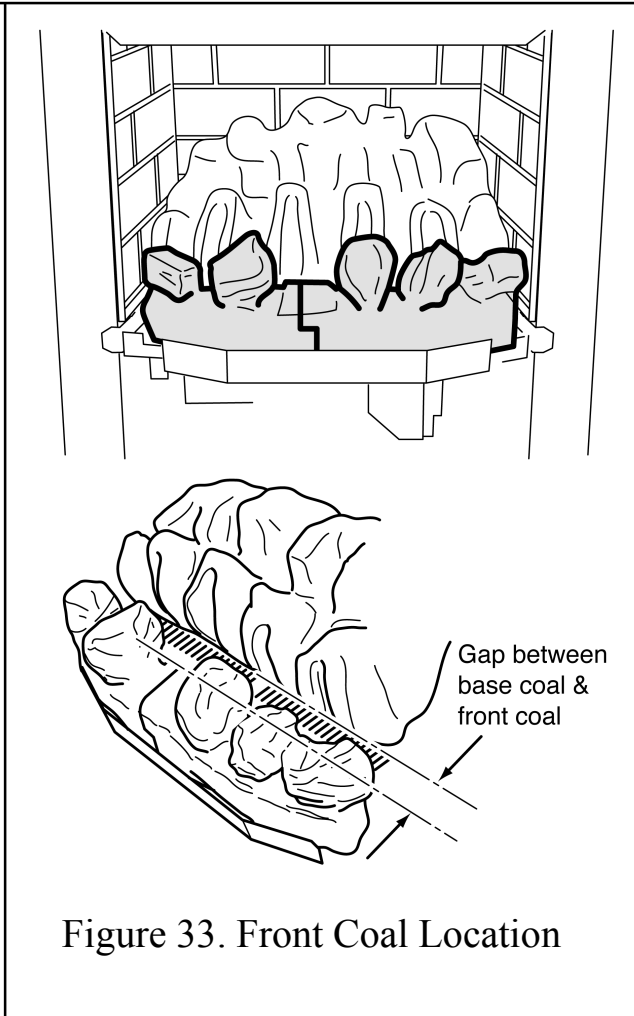

Figure 33. Front Coal Location

*(Installer - Note that the small round holes in the burner plaques that will be covered by the base coal are not gas burner ports. They are simply a consequence of the plaque manufacturing process).*

2. Place the left-hand ceramic front coal in position in front of the base coal (See figure 33).
3. Place the right hand ceramic front coal in position in front of the base coal. This should overlap the left-hand coal. Push the two sides together to minimise the gap. (See figure 33).
4. There will be a gap between the rear of the front coals and the front of the base coal. (See figure 33).

# INSTALLER'S GUIDE

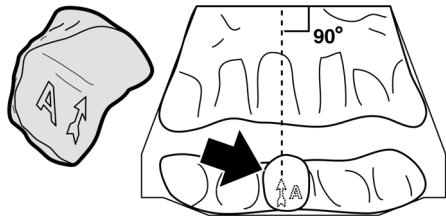

Figure 34. Front Row "Coal A"



Figure 35. Second row "Coal B"



Figure 36. Second row "Coal C"

5. Install the 12 loose coals as follows. The underside of each coal is marked with a letter 'A' to 'L' and an arrow.

6. The coals should be positioned so that the arrows always point towards the back of the firebox. When located into position the stem of each arrow should be at 90° to the rear of the firebox.

7. Hold coal 'A' upright with the arrow pointing to the top. Locate coal 'A' as shown in figure 34.

8. Locate coals 'B' to 'E' so that they are firmly seated in the valleys in the coal base and front coal.

9. Hold coal 'B' upright with the arrow pointing to the top. Locate coal 'B' as shown in figure 35.

10. Hold coal 'C' upright with the arrow pointing to the top. Locate coal 'C' as shown in figure 36.

# INSTALLER'S GUIDE



Figure 37. Second row "Coal D"

**11.** Hold coal 'D' upright with the arrow pointing to the top. Locate coal 'D' as shown in figure 37.

**12.** Hold coal 'E' upright with the arrow pointing to the top. Locate coal 'E' as shown in figure 38.

**13.** Hold coal 'F' upright with

the arrow pointing to the top. Locate coal 'F' as shown in figure 39.

**14.** This will complete the second row of loose coals.

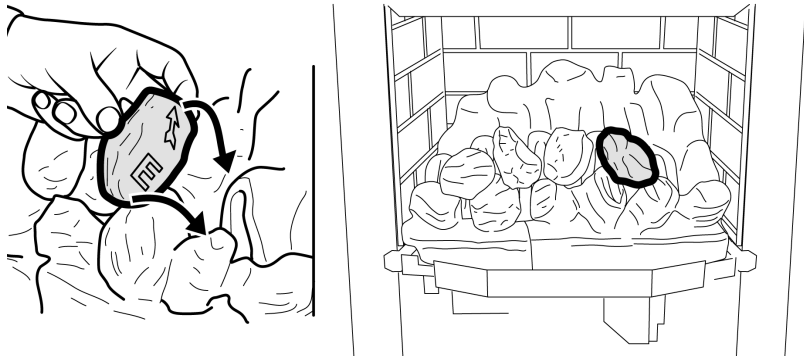

Figure 38. Second row "Coal E"

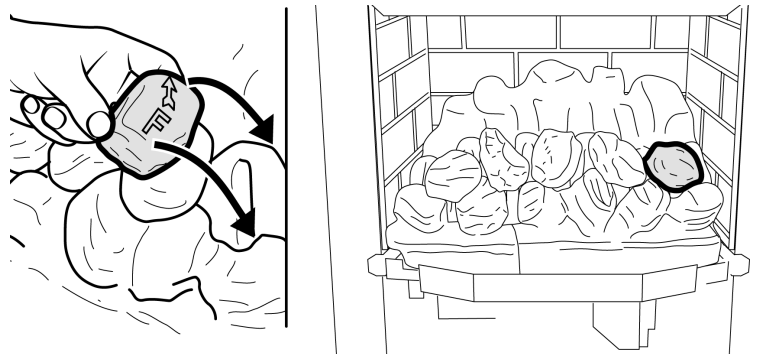

Figure 39. Second row "Coal F"



# INSTALLER'S GUIDE



Figure 40. Third row "Coal G"

**15.** Locate coals 'G' to 'K' so that they are firmly seated in the valleys in the coal base.

**16.** Hold coal 'G' upright with the arrow pointing to the top. Locate coal 'G' as shown in figure 40.

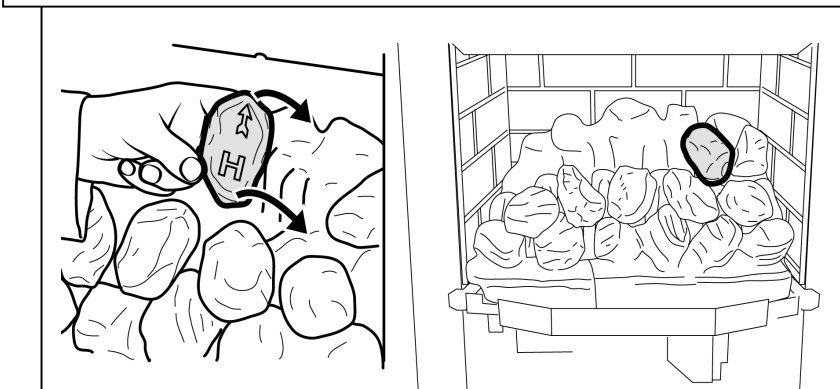

Figure 41. Third row "Coal H"

**17.** Hold coal 'H' upright with the arrow pointing to the top. Locate coal 'H' as shown in figure 41

**18.** Hold coal 'I' upright with the arrow pointing to the top. Locate coal 'I' as shown in figure 42.



Figure 42. Third row "Coal I"

# INSTALLER'S GUIDE

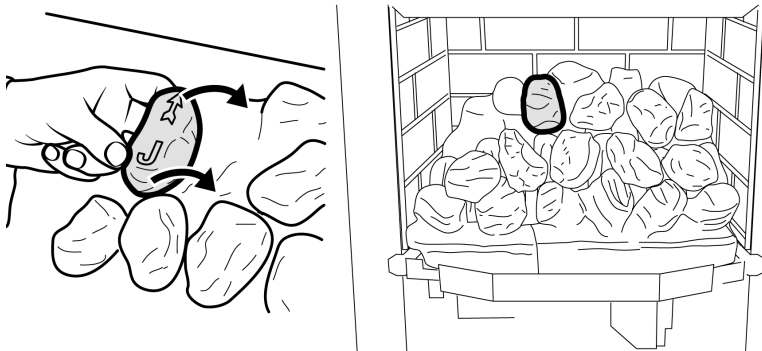

Figure 43. Third row "Coal J"

**19.** Hold coal 'J' upright with the arrow pointing to the top. Locate coal 'J' as shown in figure 43

**20.** Hold coal 'K' upright with the arrow pointing to the top. Locate coal 'K' as shown in figure 44

**21.** Hold coal 'L' upright with the arrow pointing to the top. Locate

coal 'L' as shown in figure 45



Figure 44. Third row "Coal K"

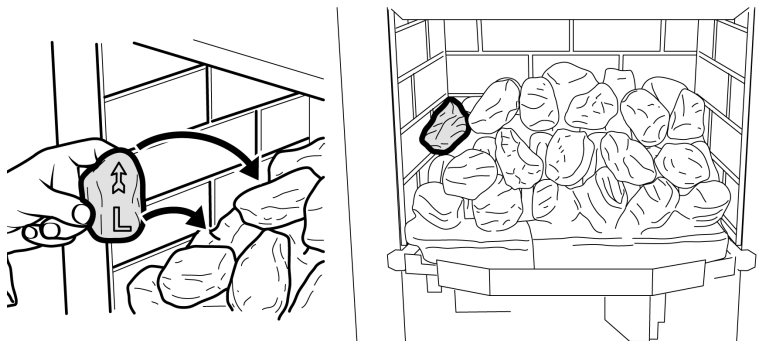

Figure 45 Third row "Coal L"

## 13 FRONT / CASTINGS INSTALLATION

1. Place the firefront casting centrally on the hearth in front of the firefront surround.
2. Place the bottom front cover casting in position below the fire front casting.

## 14 FULL OPERATING CHECKS

### 14.1 Check the Control Settings

The control position markings on the front surround are shown in figure 46.

*Please note:*

- *When first turned on from cold, the flames will appear predominantly blue.*
- *When operating the fire for the first time, some vapours may be given off which could set off smoke alarms in the vicinity. These vapours are quite normal with new appliances. They are totally harmless and will disappear after a few hours use.*

1. Make sure the slider button is at the off position (At topmost position marked “O” on the front surround).
2. Open the isolating valve on the inlet elbow.
3. Slide the button to the bottom (ignition) position marked ☆. Retain in this position to ignite the pilot. The burner should ignite at its lowest setting within 4 seconds of the pilot igniting. Keep at this position for a further 10 seconds to allow the pilot flame to stabilise.
4. Release the button. The button should automatically spring up to the low heat position. If the flames go out at this stage or when checking the rest of the setting positions, try the full lighting sequence again. If the flames fail after two attempts, investigate the pilot unit.
5. Gradually slide the button up to increase the burner setting. The burner should be at its maximum setting at the high heat position shown in figure 46. You should feel a check to the button movement at this position.
6. Slide the control button up past the high heat position to the off (“O”) position at the top of the slide slot. Both pilot and main burner should go out. While cooling the coals may make some crackling noises. This is quite normal.

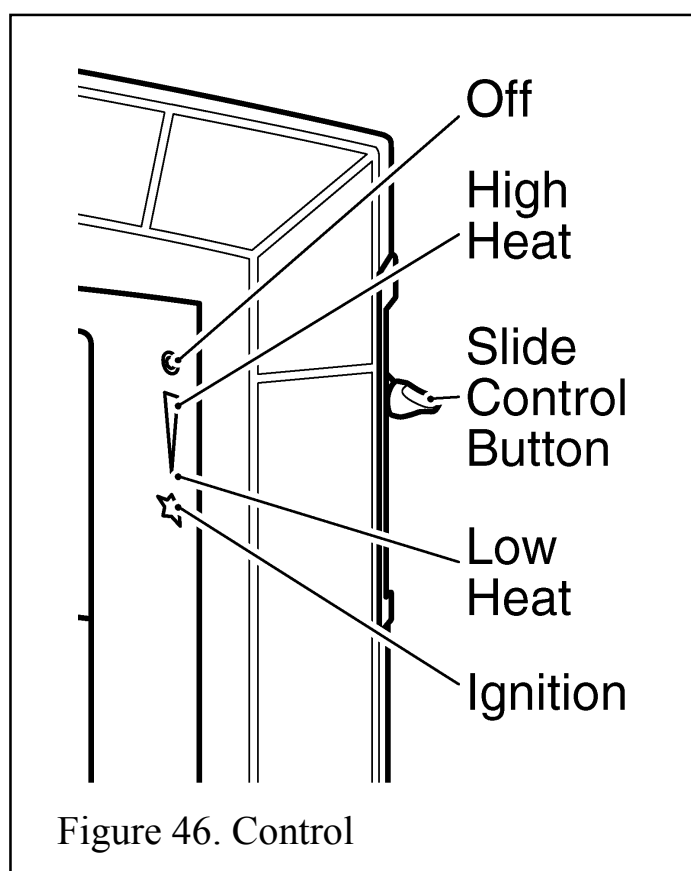

Figure 46. Control

# INSTALLER'S GUIDE

## 14.2 Check For Spillage

**A spillage check must be made before leaving the installed appliance with the customer. Make this with all the ceramic coals in position.**

1. Close all doors and windows in the room containing the appliance.
2. Light the appliance and set the slide control to the maximum burning position.
3. Leave the appliance on for five minutes.
4. The smoke match should be placed horizontally into the hotbox at the right hand side. (See figure 47).

The installation is satisfactory if the smoke is drawn into the appliance.

If the smoke is not drawn into the appliance leave the appliance alight at the maximum setting for a further ten minutes and then repeat the test. If the smoke is still not drawn into the appliance inspect the sealing to the fireplace surround. If the sealing is satisfactory but the appliance is installed with the flue restrictor (see section 7 point 8) remove the restrictor, reseal the appliance and retest. If smoke is still not drawn into the appliance **disconnect the appliance and seek expert advice.**

5. If the above test is satisfactory open all internal connecting doors, hatches, etc. in the room. Keep all doors and windows that open to the outside of the building closed.

Recheck for spillage as above. If an extractor fan is installed in the same room as the appliance or a connecting room, check that spillage does not occur with the fan operating and all doors and other openings between the fan and the appliance open.

If the smoke is drawn into the appliance, continue with the installation. If the test is not satisfactory **disconnect the appliance and advise the customer of the cause of failure.**

## 14.3 Flame Supervision & Spillage Monitoring System

This pilot unit includes a system that will automatically shut off the gas supply if the pilot flame goes out or if there is insufficient oxygen due to spillage or poor ventilation. Check that the system operates properly as follows: -

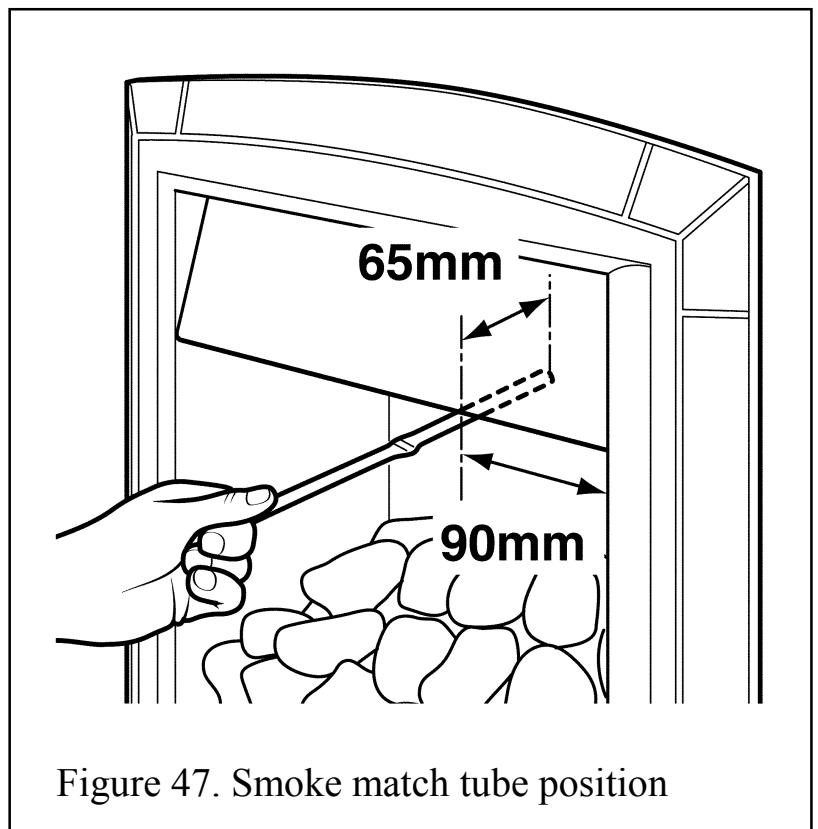

Figure 47. Smoke match tube position

# INSTALLER'S GUIDE

1. Light the appliance. Set the slide control to the maximum burning position and leave for one minute.
2. Set the control to the Low burning position. Isolate the gas supply at the inlet elbow. The pilot and main burner will go out. **Note the time when the pilot goes out.** Listen for a snap sound at the gas tap. **Note the time when the sound is heard.** This sound is caused by an electromagnetic valve shutting off the gas supply through the tap. The valve is located in the body of the tap. The valve should operate **within 60 seconds of the pilot going out.** If the valve does not operate within this time limit do not allow the appliance to be used until the fault has been corrected.  
**This monitoring system must not be adjusted, bypassed or put out of operation. This monitoring system, or any of its parts, must only be exchanged using authorised parts.**
3. Open the isolating valve on the inlet elbow. Screw on the end cap and test for leaks.
4. Set the slider to the “Off” position.

# INSTALLER'S GUIDE

## 15 FINAL REVIEW

1. If a gap is visible between the inner sides of the front surround and the ceramic side walls, gently slide the walls forward.
2. Visually inspect the appliance. Clean off any marks incurred during installation.
3. Advise the customer how to operate the appliance. Point out that lighting instruction details are on the metal plate attached at the bottom of the appliance. Explain to the customer that the appliance has a flame failure & spillage monitoring system. Point out the explanation of this system shown in the users instructions under "Operating the fire". Advise that if the fire goes out for any reason; wait at least three minutes before relighting. Stress that if the monitoring system repeatedly shuts off the fire, the appliance should be switched off and a specialist should be consulted.
4. Advise the customer that they should read their Owner's guide before operating the fire and always follow the advice in the section headed "Cleaning".
5. **Stress that no extra coals must be added over and above those supplied with the appliance and that any replacements must only be the authorised spares. Warn that ignoring this advice could cause incomplete clearance of the products of combustion with consequent health hazards.**
6. Advise the customer that the appliance will operate to its maximum potential if the flue is primed during the first 20 – 30 minutes of use. To do this, simply slide the control to its highest setting. This will also burn off any carbon deposits that may have formed during previous use.  
If using the appliance for long periods it is beneficial to change between settings. This will also help to remove any carbon deposits that may form during use.
7. Recommend that the appliance should be serviced by a competent person at least annually.  
If the appliance is in premises in the United Kingdom occupied by a tenant, point out that by law a landlord must have any gas appliance, flue and pipework which is situated in a tenant's premises checked for safety at least every 12 months.
9. Advise that the fire may give off a slight odour while new. This is quite normal and it will disappear after a short period of use.
10. Hand the literature pack with this guide to the customer.

## 16 SERVICING & PARTS REPLACEMENT

Always turn off the gas supply before commencing any servicing (The appliance inlet “T” connector incorporates an isolating valve).

It is recommended that, at least once a year, the appliance is disconnected and the fireplace opening checked and cleared of any debris.

This product uses fuel effect pieces, burner compartment walls and gaskets containing Refractory Ceramic Fibres (RCF), which are man-made vitreous silicate fibres. Excessive exposure to these materials may cause irritation to eyes, skin and respiratory tract. Consequently, it is important to take care when handling these articles to ensure that the release of dust is kept to a minimum. To ensure that the release of fibres from these RCF articles is kept to a minimum, during installation and servicing we recommend that you use a HEPA filtered vacuum to remove any dust and soot accumulated in and around the fire before and after working on the fire. When replacing these articles we recommend that the replaced items are not broken up, but are sealed within a heavy duty polythene bag, clearly labelled as RCF waste. This is not classified as “hazardous waste” and may be disposed of at a tipping site licensed for the disposal of industrial waste. Protective clothing is not required when handling these articles, but we recommend you follow the normal hygiene rules of not smoking, eating or drinking in the work area and always wash your hands before eating or drinking.

### 16.1 Checking the aeration setting of the burner.

- **The aeration collar is factory set.** If the gap at the rear of the mixer tube is different to that shown in figure 48 see below.
- The aeration collar should be positioned so that the opening in the rear of the mixer tube is partially closed. Slide the aeration collar towards the injector as far as it will go. The gap should be 4mm (See figure 48).

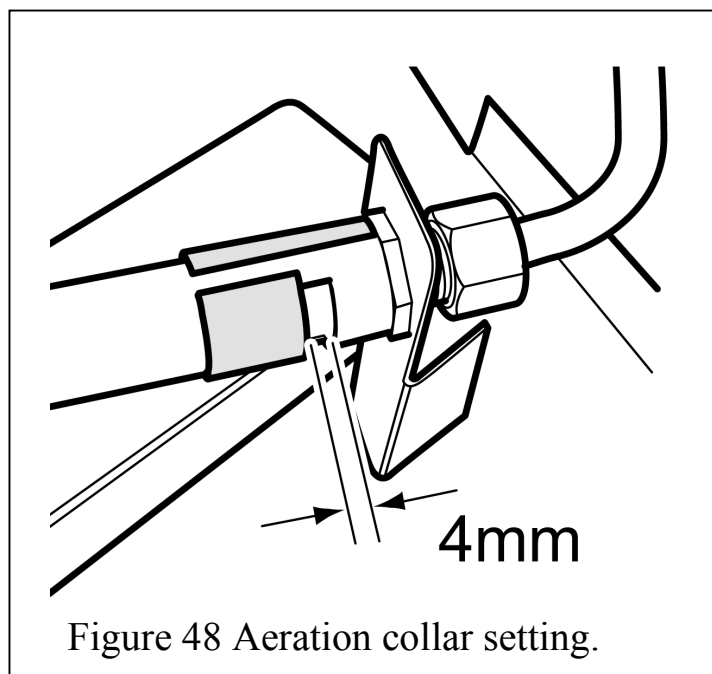

Figure 48 Aeration collar setting.

# INSTALLER'S GUIDE

- Check that the appliance is clean and that soot or debris is not blocking the gaps between the coals causing an imperfect flame.
- Check that soot or debris is not impairing the electrode spark or pilot burner.
- Check that soot or debris is not blocking any of the slots in the main burner.
- After servicing, make sure that the ceramic walls and coals are replaced correctly as described in the installation instructions.
- **Always test for gas soundness and spillage after servicing the appliance.**

## 16.2 To Remove the Ignition Microswitch

See figures 49 & 50.

*The ignition microswitch is stamped V4NT9C4YC*

1. Remove the bottom front cover and the fire front casting.
2. Remove the burner baffle by sliding upward.
3. Detach the microswitch cover by removing one screw and pulling clear of the location lug. See figure 49.
4. Disconnect the leads from the ignition microswitch (The lower of the two microswitches - See figure 50).
5. Detach the microswitch and insulation pad by removing two screws.
6. Replace in the reverse order. Check that the microswitch operates correctly by fully closing it and observing that there are sparks at the pilot electrode.

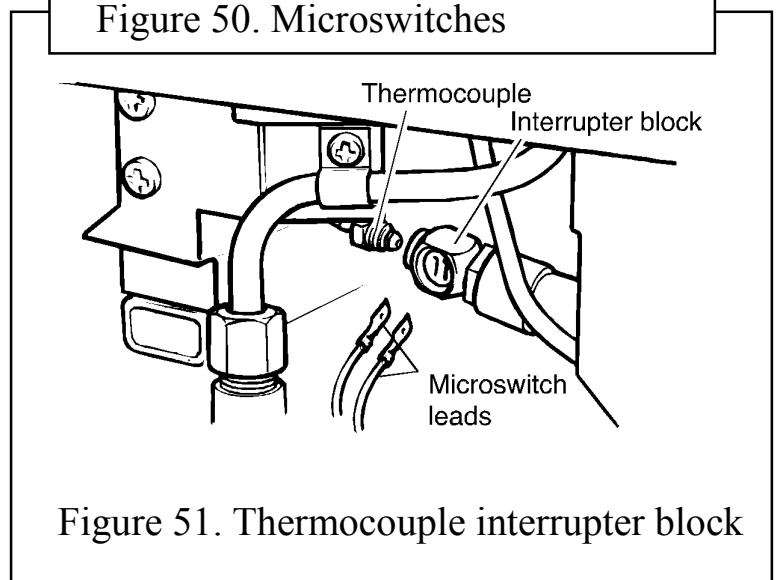
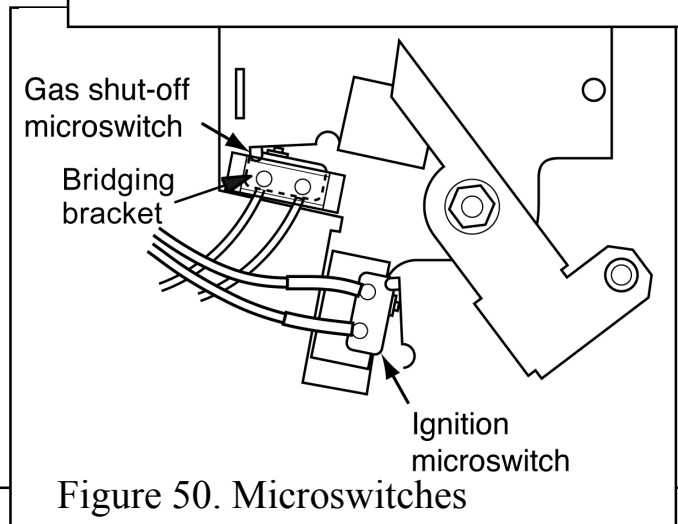
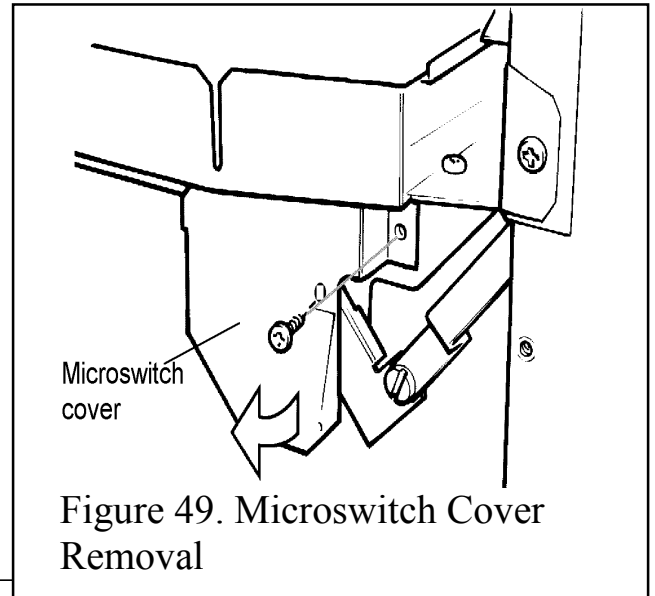



## 16.3 To Remove the Gas Shut-Off Microswitch

See figures 49, 50 & 51.

*The gas shut-off microswitch is stamped V4NT9C2YCGPX or V4NT9C2YCAUX.*

1. Remove the bottom front cover and the fire front casting.
2. Remove the burner baffle by sliding upward.
3. Detach the microswitch cover by removing one screw and pulling clear of the location lug. See figure 49.
4. Loosen the thermocouple nut to free the microswitch leads and pull the leads clear of the thermocouple interrupter block. See figure 51.
5. Detach the bridging bracket, microswitch assembly and insulation pad by removing two screws. See figure 50.
6. Replace in the reverse order. When refitting the leads to the interrupter block, make sure that they are secured firmly to give a good electrical contact.

## 16.4 To Remove the Fire Front Surround

1. Remove the bottom front cover and the fire front casting.
2. Remove the burner baffle by sliding upward.
3. Detach the control-linking bar from the control pivot bracket by removing the knurled screw, which joins the control linking bar to the control pivot unit. See figure 52.
4. Remove the two screws and washers securing the bottom of the front surround to the sides of the hotbox. See figure 53.
5. **Make sure that the control linking bar**

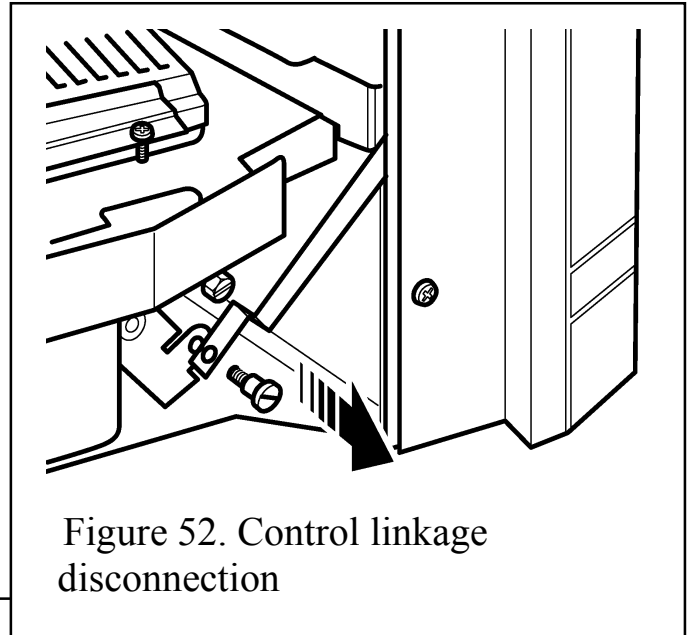

Figure 52. Control linkage disconnection

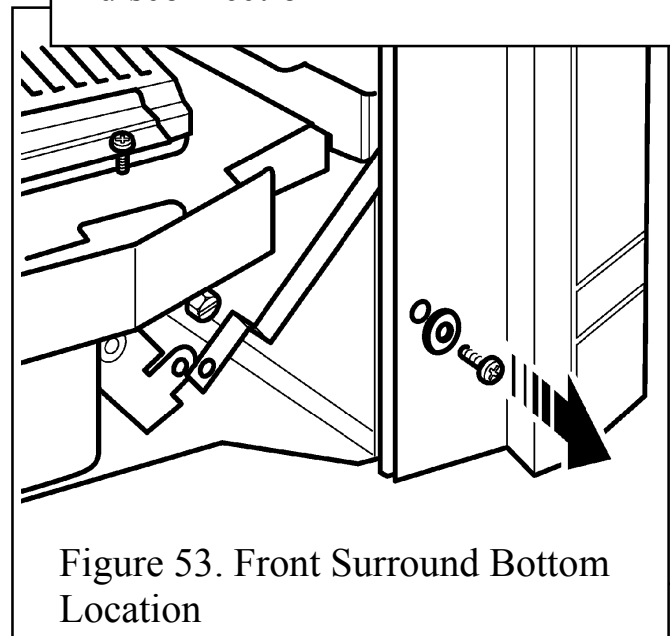

Figure 53. Front Surround Bottom Location

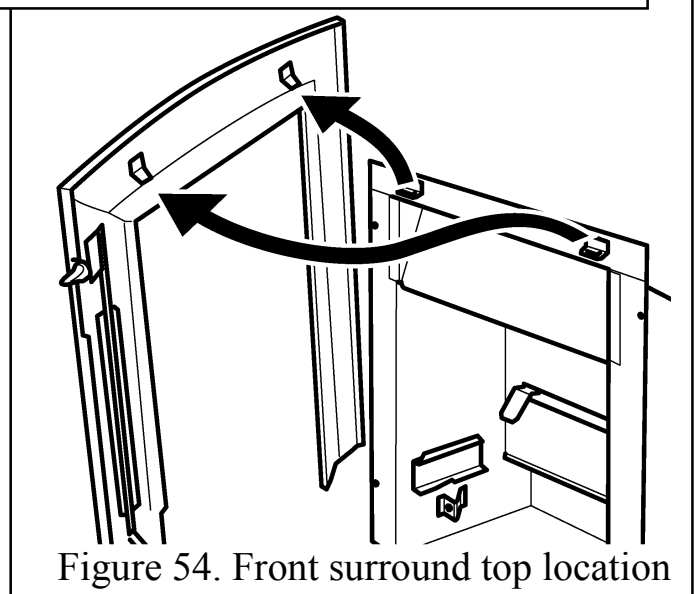

Figure 54. Front surround top location

# INSTALLER'S GUIDE

has been detached (See 3 above). Carefully lift the surround unit upward to clear the upper retaining brackets on the hotbox - See figure 54. Pull the surround clear and place carefully aside.

6. Refit in the reverse order. Make sure that the surround is properly located over the upper retaining brackets. See section 11 of this manual for detailed fitting instructions.

## 16.5 To Replace the Control Slide Unit

1. Remove the front surround - See section 16.3.
2. Remove the burner baffle by sliding upward.
3. Detach the slide unit by removing two screws securing the plastic slide mechanism to the rear of the front surround - See figure 55.
4. Replace in the reverse order.

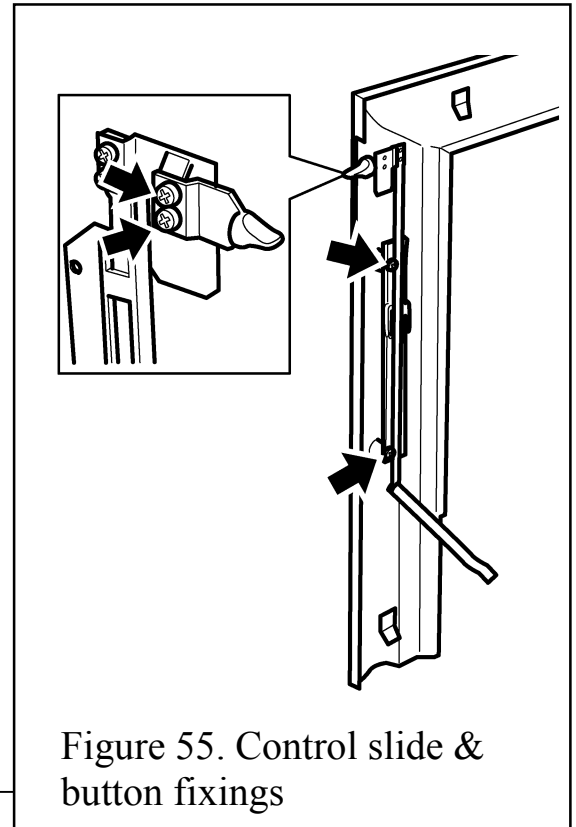

Figure 55. Control slide & button fixings

## 16.6 To Replace the Control Slide Button

1. Remove the front surround - See section 16.4.
2. Detach the slide button by removing two screws - See figure 55.
3. Replace in the reverse order.

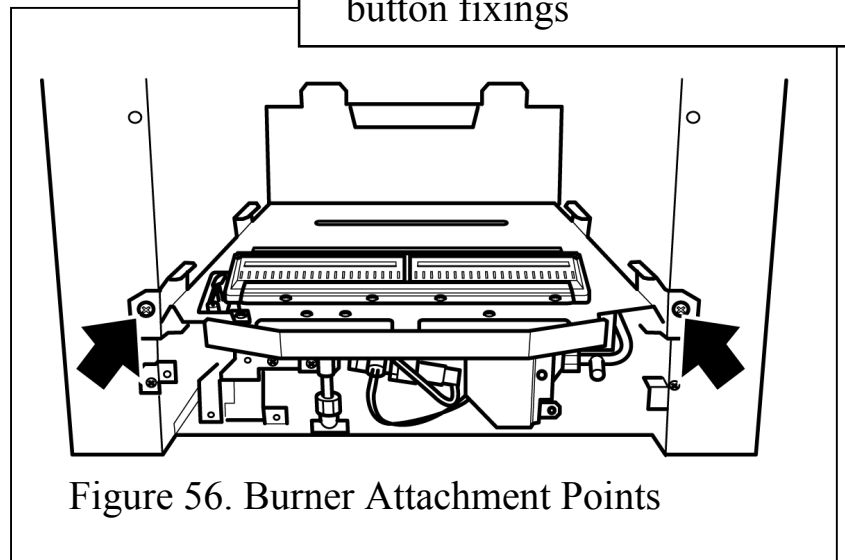

Figure 56. Burner Attachment Points

## 16.7 To Remove the Burner Unit

1. Remove the bottom front and fire front castings and the front surround - See section 16.3.
2. Remove the loose coals, the front coal and the base coal.
3. Support the inlet isolating elbow to avoid straining the pipework and disconnect the appliance from the elbow.
4. Detach the burner unit from the hotbox by removing two screws - See figure 56.
5. Replace in the reverse order.

## 16.8 To Remove the Electronic Ignition Generator

1. Remove the bottom front and fire front castings and the front surround - See section 16.3.

# INSTALLER'S GUIDE

2. Remove the battery.
3. Remove the burner unit – see section 16.6.
4. If lying the burner on its back, unscrew and remove the two ceramic support brackets from the top of the burner unit. This will avoid damage to the brackets and the work surface (see figure 57).
5. Remove the spark lead
6. Unscrew the pipe clamp and two support bracket screws. The generator and its support bracket can now be moved forward. Be careful not to apply tension to the microswitch leads.
7. Remove the two fixing screws that attach the generator unit to the support bracket. The igniter generator can now be removed. (see figure 58)
8. Remove the two leads to the switch and remove the spark lead. If necessary, mark them to ensure that they are replaced on to the correct terminals.
9. Replace the generator
10. Refit in the reverse order.

## 16.9 To Remove the Thermocouple Interrupter Block

See figure 59.

1. Remove the bottom front and fire front castings and the front surround - See section 16.3.
2. Detach the thermocouple from the interrupter block by unscrewing the thermocouple nut.
3. Detach the two microswitch leads from the interrupter block.

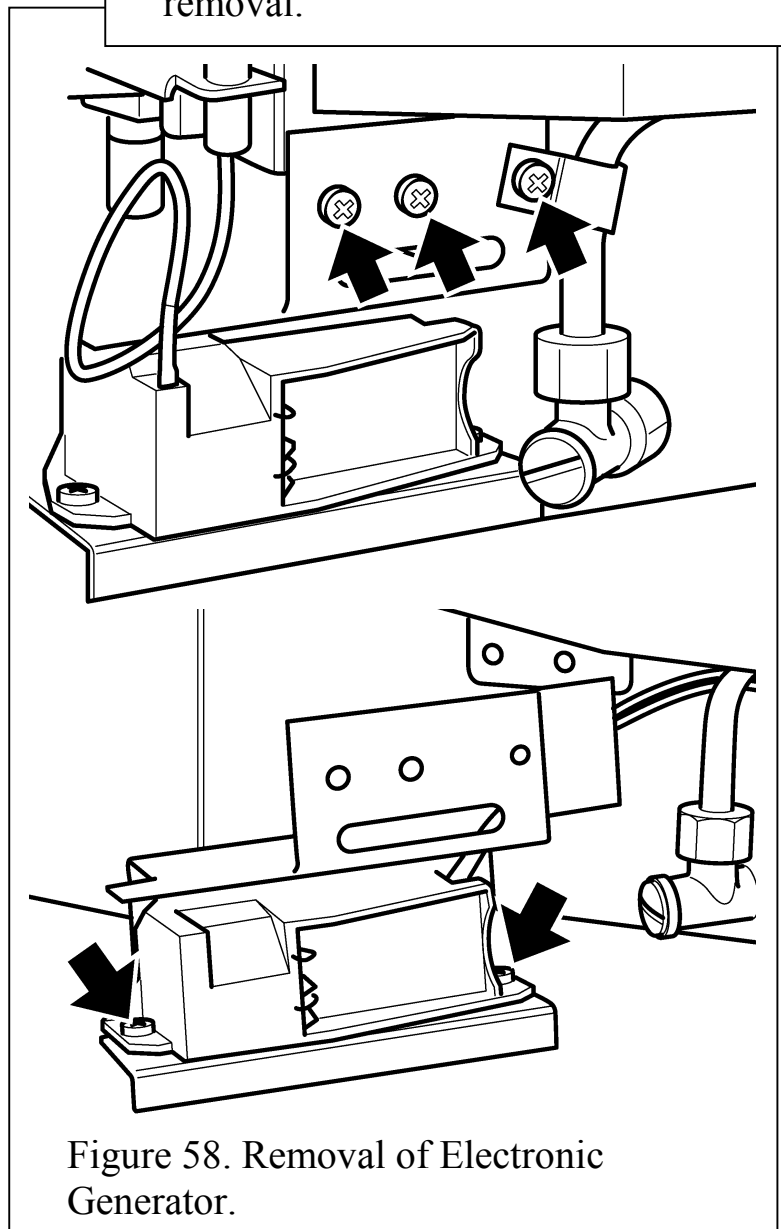
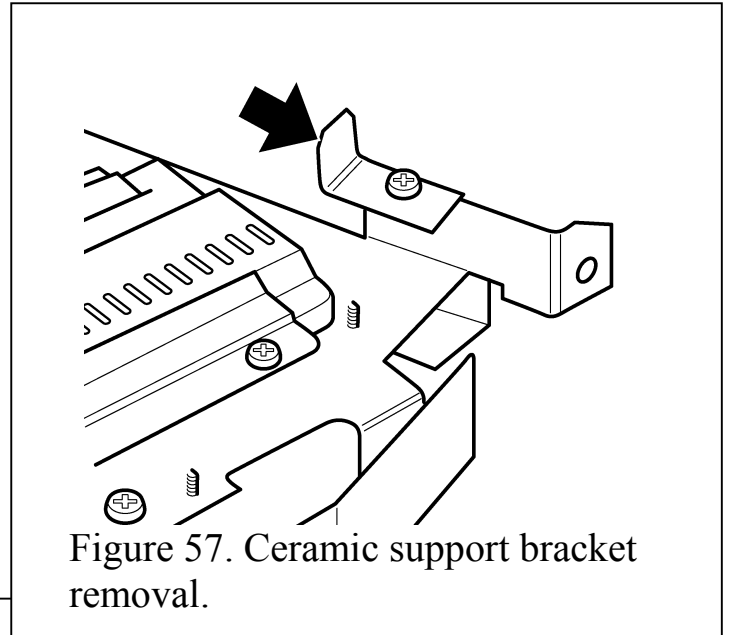

# INSTALLER'S GUIDE

4. Remove the interrupter block by unscrewing from the gas shut-off tap.

5. Refit in the reverse order. If the microswitch leads cannot be easily attached to the interrupter block when it is fully tightened to the gas shut-off tap, slacken it and rotate to allow the leads to be fitted. Retighten making sure that the leads remain in place in the interrupter block. Fit and tighten the thermocouple nut making sure that the leads are secured in the interrupter block to give a good electrical contact.

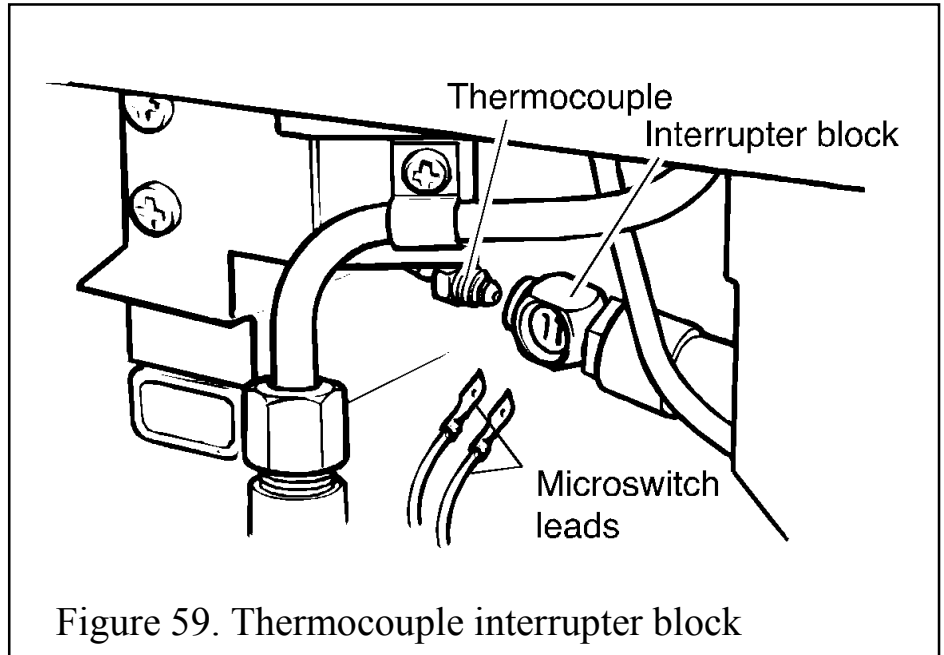

## 16.10 To Remove the Pilot Unit

7. Remove the burner unit - See section 16.6.

8. If lying the burner on its back, unscrew and remove the two ceramic support brackets from the top of the burner unit. This will avoid damage to the brackets and the worksurface (see figure 57)

9. Detach the pilot pipe from the gas shut-off tap.

10. Detach the thermocouple from the interrupter block by unscrewing the thermocouple nut.

11. Detach the electrode lead from the underside of the electrode tab.

12. Remove the first screw securing the dust cage to the pilot unit & burner. Carefully remove the dust cage and place aside. See figure 60.

13. Remove the second screw securing the pilot unit to the burner. Remove the pilot unit and place it aside. See figure 60.

14. Disconnect the pilot pipe from the pilot unit elbow.

15. Refit in the reverse order.

*Note: 1. The pilot unit is an atmosphere sensing device. It must be replaced as a whole assembly. Its individual components are not separately replaceable.*

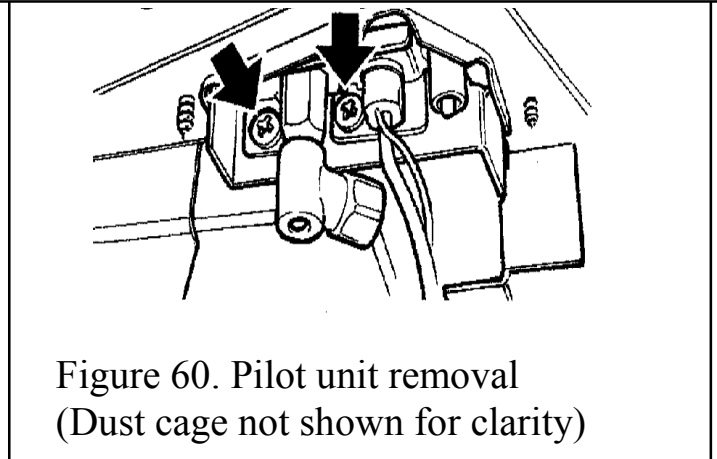

# INSTALLER'S GUIDE

2. *Once removed, ensure that the dust cage is cleaned before refitting. Make sure that it locates squarely onto the pilot unit without any gaps between the cage edges and the pilot unit.*
3. *When the thermocouple is removed from the interrupter block, the microswitch lead terminals in the interrupter block will be loose. Make sure that they are properly secured to give a good electrical contact when retightening the thermocouple nut.*

## 16.11 To Remove the Shut-Off Tap

See figure 61.

1. Remove the burner unit - See section 16.6.

2. Unscrew and remove the two ceramic support brackets from the top of the burner unit. This will avoid damage to the brackets and the worksurface (see figure 57) Turn the burner unit upside down. Detach the thermocouple and interrupter block from the tap - See section 16.8 paragraphs 2 - 4.

3. Detach the pilot pipe from the tap.

4. Detach the inlet pipe.

5. Remove the hexagonal nut securing the tap to the mounting bracket.

6. Detach the elbow by unfastening the hexagonal nut connecting it to the flow rate controller. Lift the tap (complete with elbow) clear.

7. Loosen the hexagonal locknut securing the elbow to the tap. Remove the elbow by rotating it.

8. If fitting a new tap, remove the hexagonal nut at the mounting bracket end of the old tap and fit to the replacement tap. Refit in the reverse order. When refitting, make sure that the tap spindle is in the correct relationship relative to the control pivot bracket. Rotate the pivot bracket fully clockwise. The tap spindle should "bottom out" (i.e. the tap should be fully open) after the pivot bracket has actuated the ignition microswitch but before it has pushed the microswitch leaf against the microswitch body.

When refitting the thermocouple and interrupter block, make sure that the microswitch wires are properly secured to give a good electrical contact.

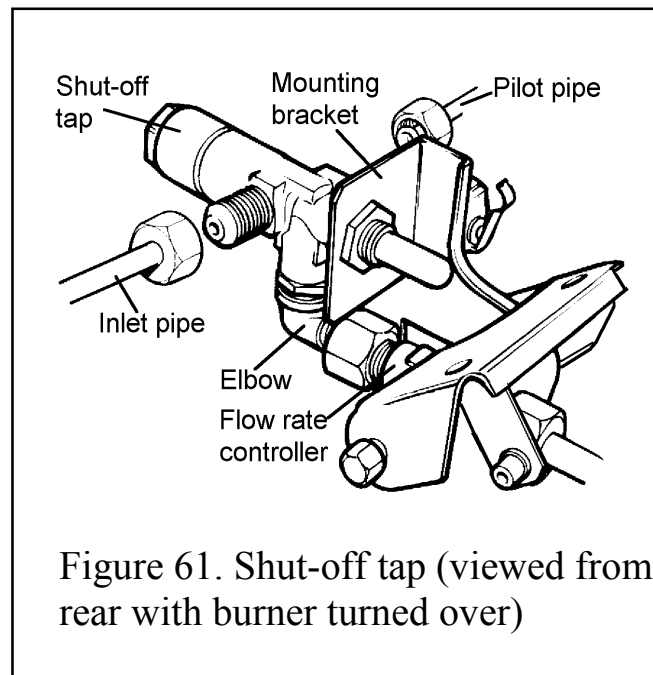

## 16.12 To Remove the Gas Flow Rate Controller

See figure 62.

1. Remove the burner unit - See section 16.6.
2. If lying the burner on its back, unscrew and remove the two ceramic support brackets from the top of the burner unit. This will avoid damage to the brackets and the worksurface (see figure 57)
3. Detach the microswitch cover - See section 16.1 paragraph 2.
4. Detach the shut-off tap as detailed in section 16.11 paragraphs 2-6.
5. Detach the burner pipe from the

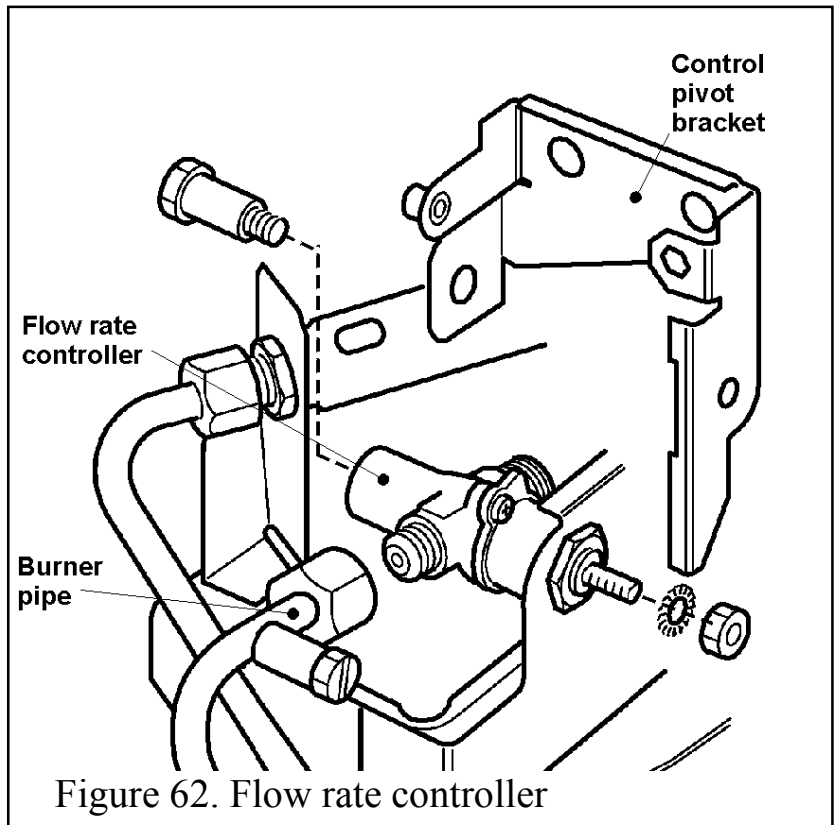

- controller. Support the controller while detaching to prevent excessive strain.
6. Remove the nut and washer securing the control pivot bracket to the controller at the front. Support the pivot bracket while removing the nut to prevent possible damage to the microswitch.
  7. Remove the hexagonal bolt securing the control pivot bracket to the controller at the rear.
  8. Detach the control pivot bracket.
  9. Remove the hexagonal nut securing the controller to the front mounting bracket and remove the flow rate controller.
  10. Refit in the reverse order.

## 16.13 To Remove the Main Burner Injector

See figure 63.

1. Remove the burner unit - See section 16.6.

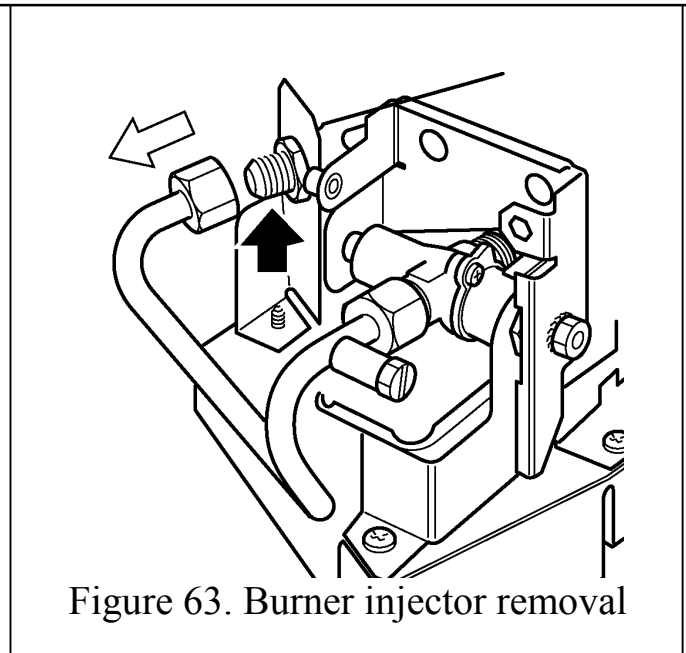

## INSTALLER'S GUIDE

2. If lying the burner on its back, unscrew and remove the two ceramic support brackets from the top of the burner unit. This will avoid damage to the brackets and the worksurface (see figure 57)

3. Disconnect the main burner pipe from the injector at the venturi end. If necessary, loosen the pipe at the flow rate controller end to swing the pipe clear of the injector.

4. Unscrew the injector from the rear support bracket.

5. Refit in the reverse order.

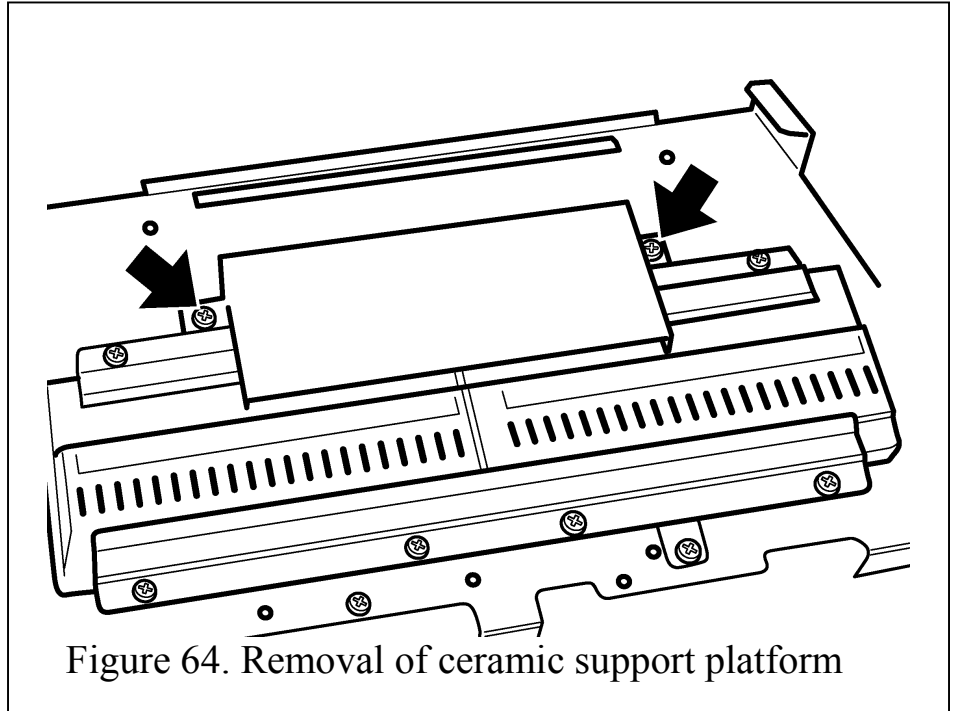

Figure 64. Removal of ceramic support platform

## 16.14 To Replace Burner Plaques

See figure 65.

1. Remove the bottom front and fire front castings.
2. Remove the loose coals, the front coals and the base coal.
3. The plaques can be then be removed as follows without detaching the front surround or ceramic walls but ***be careful not to damage the ceramic walls while working inside the firebox.***
4. Remove the ceramic support platform by detaching 2 screws (See figure 64
5. Remove the plaque clamping strips by detaching 8 screws.
6. Remove the plaques and the combination gasket between and under the plaques. If necessary remove the gauze and the gasket beneath it.
7. If necessary fit a new gasket below the gauze. Clean and replace the gauze. Fit a new combination gasket below the plaques. Push the gasket ends inwards to form a dividing gasket between the plaques.
8. Place the new left hand plaque in position. The left side of the plaque must touch the inside edge of the retaining flange at the left side of the burner well.
9. Place the new right hand plaque in position. Make sure that the centre section of the combination gasket is between the two plaques. If there is any play between the plaques and the end retaining flanges, push the plaques firmly to the left squeezing the centre section of the combination gasket between the two plaques. Any gap should be between the right side of the plaque and the right side-retaining flange.
10. Fit the front and rear plaque clamping strips. Make sure that the plaques are as far to the left as possible. ***It is important that the left side plaque is accurately positioned so that it has the correct relationship to the pilot.*** Fully tighten the clamping strips.
11. Refit the coals as described in section 12 of this manual. Refit the bottom castings.

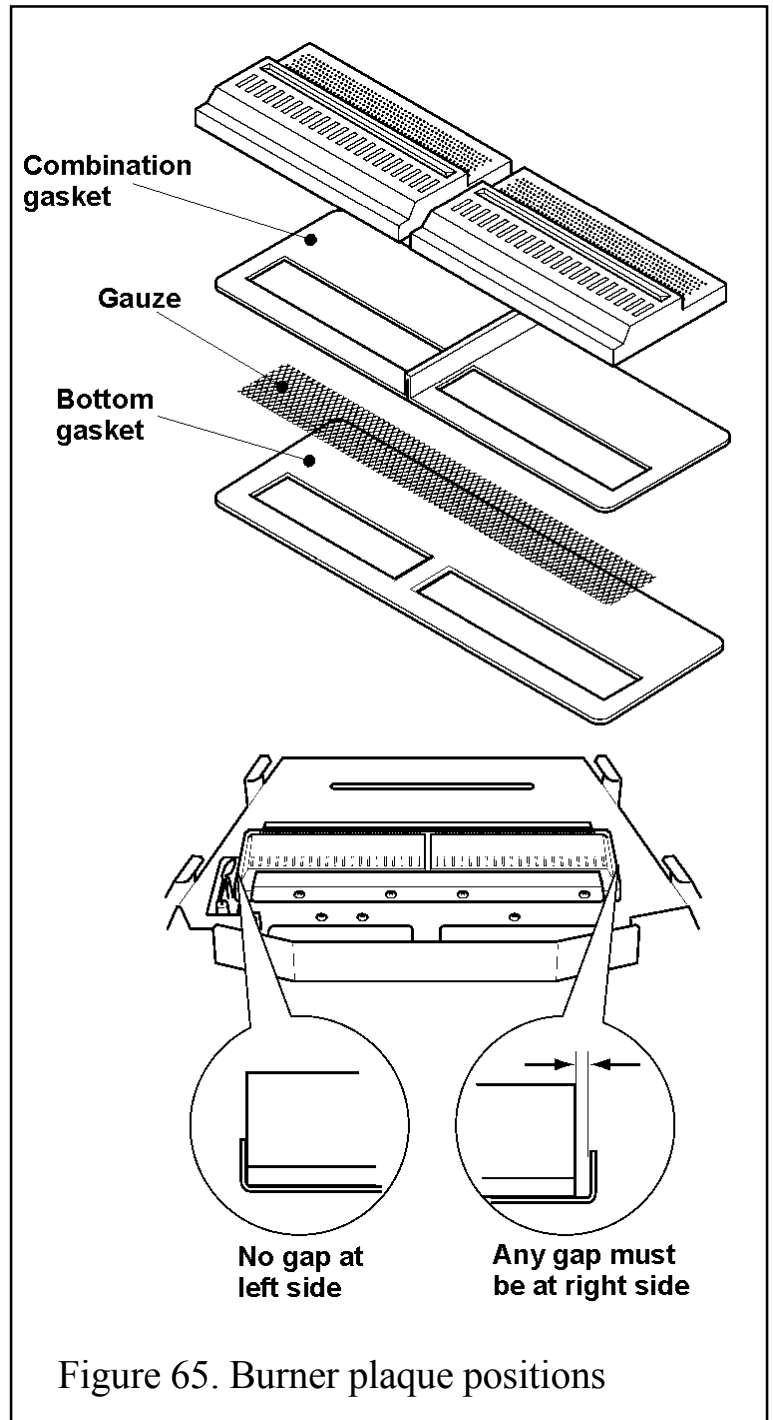

Figure 65. Burner plaque positions



## **16.15 To Remove the Appliance from the Fireplace**

**1.** Remove the burner unit - See section 16.6.

If the fire retention is as method 1 (See section 8.1 of installation instructions), remove the screws.

If the fire retention is as method 2 (See section 8.2 of installation instructions), slacken the hexagonal adjusters on the cable retainers and unscrew the thumbscrews to release the cables.

**2.** Refit as described in the relevant installation sections. Make sure gas soundness, sealing, spillage test and performance are satisfactory.

# INSTALLER'S GUIDE

## 17 SHORT LIST OF SPARES

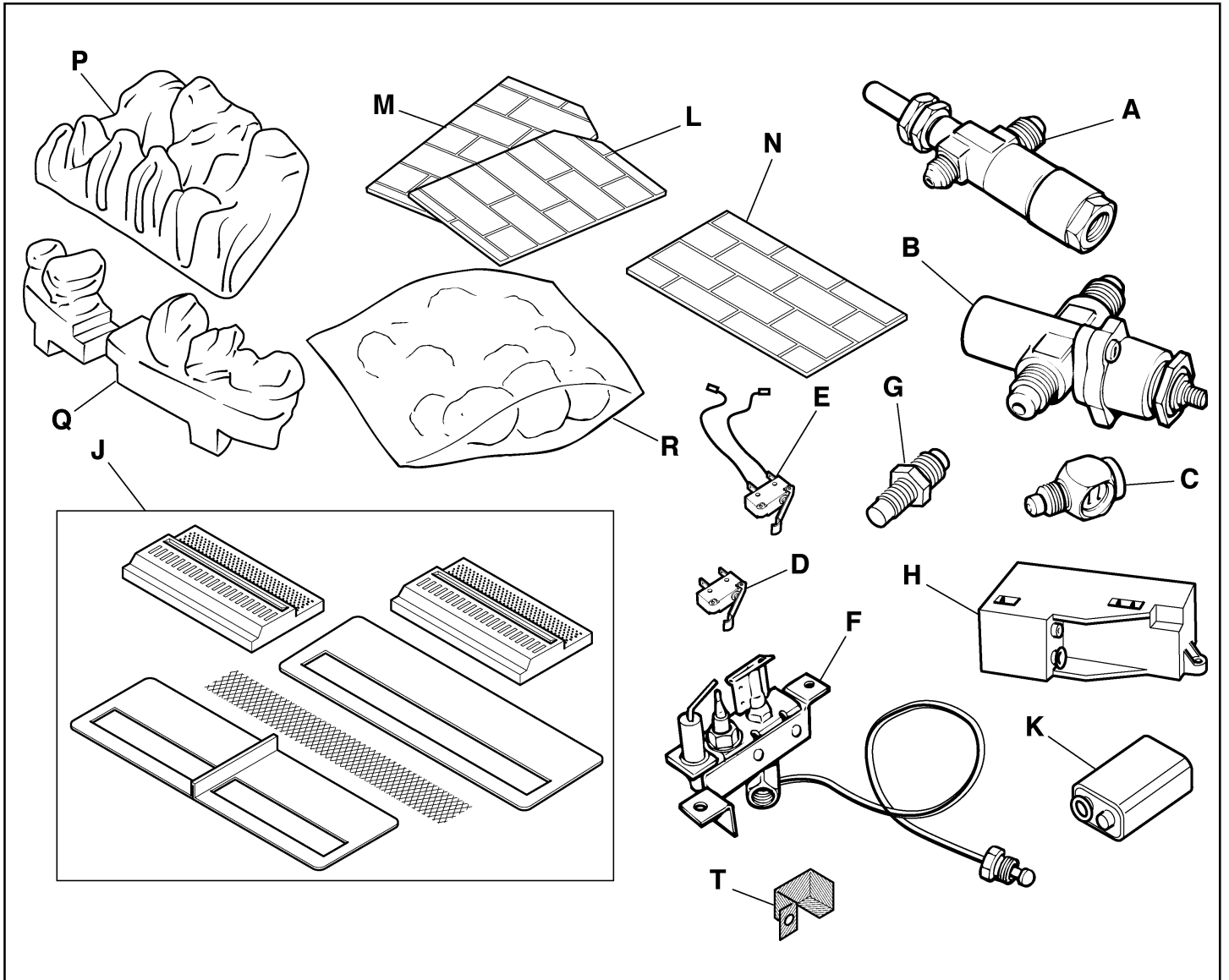

# INSTALLER'S GUIDE

KEY NO.	DESCRIPTION	NO. OFF	MAKER'S PART NO.
A	Shut-off tap	1	730K146
B	Gas flow rate controller	1	730K147
C	Thermocouple interrupter block	1	720A142
D	Ignition microswitch	1	720A269
E	Gas shut-off microswitch	1	020K931
F	Pilot unit - <i>For Natural Gas Appliances</i>	1	720A249
	Pilot unit - <i>For Propane Gas Appliances</i>		720A300
G	Injector Bray cat 18U size 420 - <i>For Natural Gas Appliances</i>	1	720A072
	Injector Stereomatic size 170 and carrier - <i>For Propane Gas Appliances</i>		3002350
H	Igniter unit	1	730K180
J	Burner plaque & gasket set	1	000B235
K	Battery 9V Size "PP3"	1	700K706
L	Ceramic left side wall	1	3002107
M	Ceramic right side wall	1	3002109
N	Back wall	1	3002108
P	Base coal	1	3002190
Q	Front coal set	1	3002330
R	Pack of loose coals	1	3002193
S	Dust cage	1	320B282